

Slipcover Counter Stool

Taburete de Barra con Funda

dpcci # 249-01-0030

dpcci # 249-01-0030

style # TG104-0355

estilo # TG104-0355

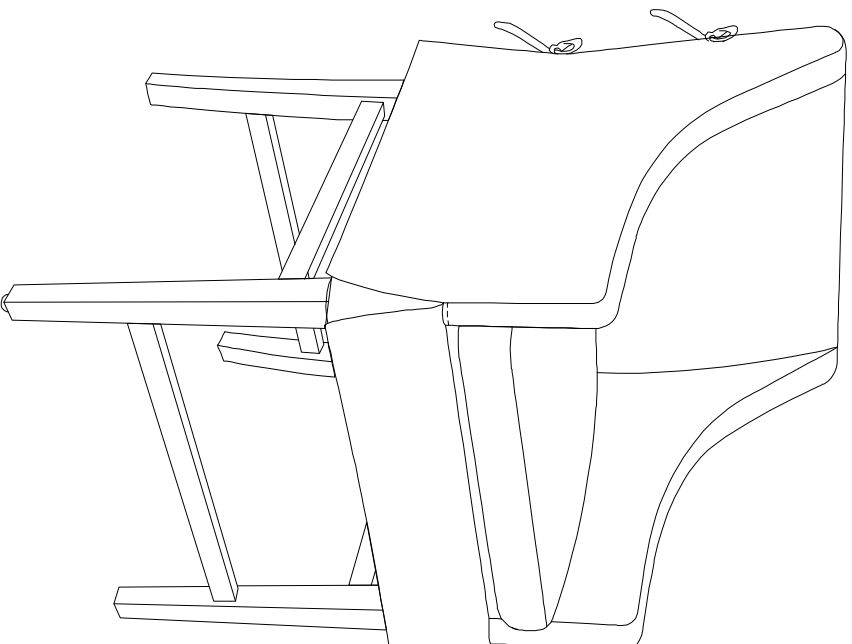

>> assembly instructions

>> Instrucciones de ensamblaje

© 2024 Target. The Bullseye Design is a trademark of Target Brands, Inc. All rights reserved.

© 2024 Target. El Diseño del Ojo de Toro es una marca comercial de Target Inc. Todos los derechos reservados.



Congratulations on your latest Target purchase.

Now what? Don't start sweating over this box of parts. This will be easy. We did the hard work for you. All you need to do is follow our simple instructions and you'll be on your way to transforming your room in no time. Good luck ---- though we're confident you won't need it.

before you begin

1. Check for damaged or missing parts. Call 1-855-MY TGT HOME (1-855-698-4846) to order missing supplies.
2. Use the carton as a working surface to prevent product damage during assembly.
3. Gather all tools prior to assembly.

Tools needed (Not included)

Herramientas necesarias (No incluidas)

SCREW DRIVER

DESTORNILLADOR



Felicitaciones por su reciente compra en Target.

¿Ahora que? No empieces a sudar por esta caja de piezas. Esto será fácil. Hicimos el trabajo duro por usted. Todo lo que necesita hacer es seguir nuestras sencillas instrucciones y estará en camino de transformar su habitación en poco tiempo. Buena suerte ---- aunque estamos seguros de que no la necesitarás.

antes de que empieces

1. Verifique si faltan piezas o están dañadas. Llame al 1-855-MY TGT HOME (1-855-698-4846) para solicitar los suministros faltantes.
2. Utilice la caja como superficie de trabajo para evitar daños al producto durante el montaje.
3. Reúna todas las herramientas antes del montaje.

hardware

(H1) x 8
bolt (M8x60mm)
perno

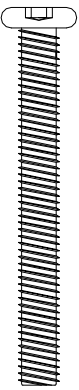

(H2) x 8
lock washer
arandela de seguridad



(H3) x 8
flat washer
arandela plana



(H4) x 8
screw (M4x45mm)
tornillo



(H5) x 1
hex wrench
llave hexagonal

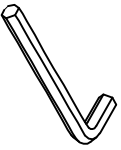

exploded diagram

ITEM	DESCRIPTION	QTY
A	counter stool body	1
B	seat cushion	1
C	right front leg	1
D	left front leg	1
E	right back leg	1
F	left back leg	1
G	side crossbar	2
I	front crossbar	1
J	back crossbar	1

diagrama de despiece

PIEZA	DESCRIPCIÓN	QTY
A	cuero del taburete de mostrador	1
B	cojín del asiento	1
C	pierna delantera derecha	1
D	pierna delantera izquierda	1
E	pierna trasera derecha	1
F	pierna trasera izquierda	1
G	travesaño lateral	2
I	travesaño delantero	1
J	travesaño trasero	1

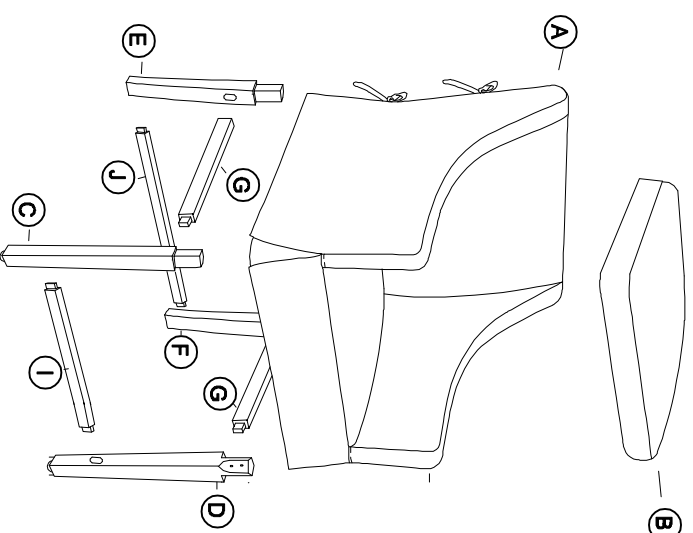

step 1: Attach right back leg to counter stool body.

paso 1: Conecte la pata trasera derecha al cuerpo del taburete del mostrador.

(H1) x 2
bolt (M8x60mm)
perno



(H2) x 2
lock washer
arandela de
seguridad



(H3) x 2
flat washer
arandela plana



(H5) x 1
hex wrench
llave hexagonal

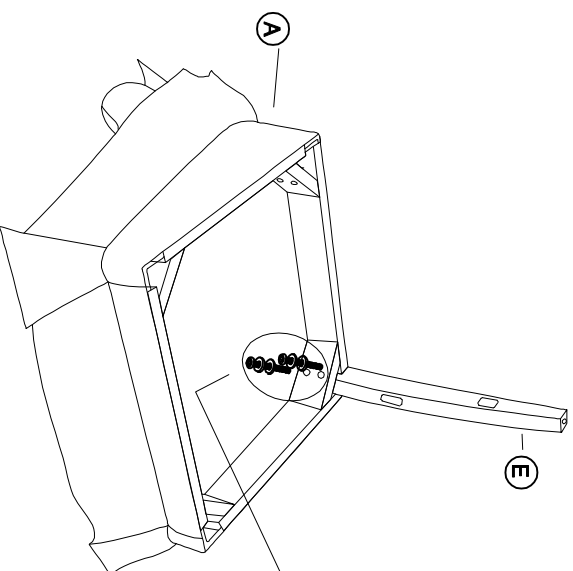
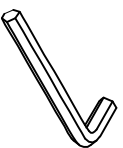

Note: Loosely attach bolts (don't securely tighten bolts) in this step.
Nota: Coloque los pernos sin apretar (no los apriete firmemente) en este paso.

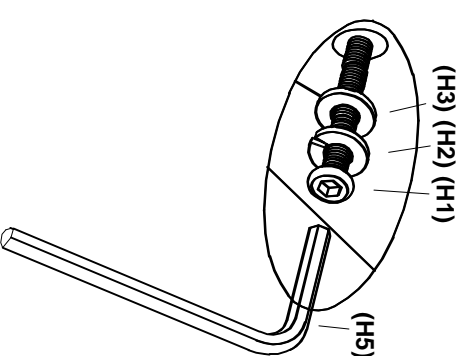

Assemble the counter stool on a soft, scratch-free surface such as a carpet or a rug.

Attach right back leg (E) to counter stool body (A) , using bolt (H1), lock washer (H2), flat washer (H3) by hex wrench(H5).

Assemble the counter stool on a soft, scratch-free surface such as a carpet or a rug.

Attach right back leg (E) to counter stool body (A) , using bolt (H1), lock washer (H2), flat washer (H3) by hex wrench(H5).

step 2: Attach back crossbar to back legs and loosely attach left back leg to counter stool body

passo 2: Fije la barra transversal trasera a las patas traseras y fije sin apretar la pata trasera izquierda al cuerpo del taburete del mostrador.

(H1) x 2
bolt (M8x60mm)
perno

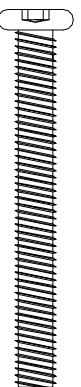

(H2) x 2
lock washer
arandela de
seguridad



(H3) x 2
flat washer
arandela plana



(H5) x 1
hex wrench
llave hexagonal

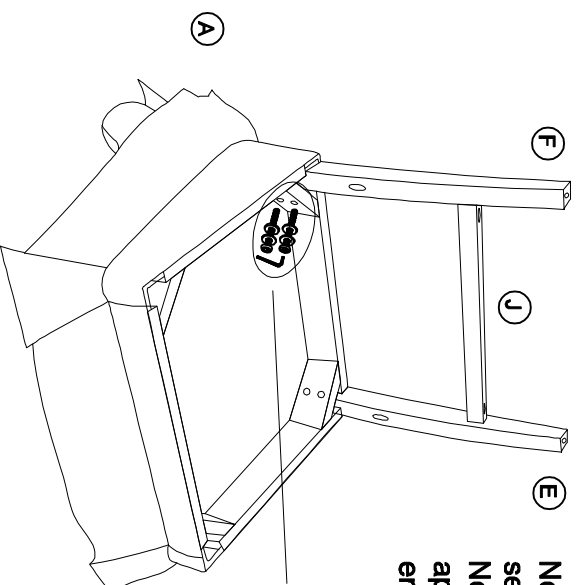
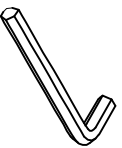

Note: Loosely attach bolts (don't securely tighten bolts) in this step.
Nota: Coloque los pernos sin apretar (no los apriete firmemente) en este paso.

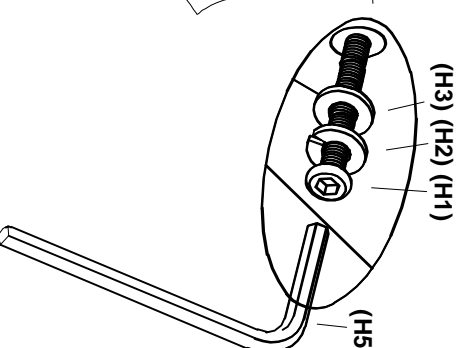

Attach back crossbar (J) to back legs (E and F) and loosely attach left back leg (F) to counter stool body (A), using bolt (H1), lock washer (H2), flat washer (H3) by hex wrench(H5).

Conecte la barra transversal trasera (J) a las patas traseras (E y F) y fije sin apretar la pata trasera izquierda (F) al cuerpo del taburete (A), usando el perno (H1), la arandela de seguridad (H2) y la arandela plana (H3) por hexágono. llave (H5).

step 3: Attach side crossbar to back leg and front leg and loosely attach left front leg to counter stool body.

Paso 3: Fije la barra transversal lateral a la pata trasera y a la pata delantera y fije sin apretar la pata delantera izquierda al cuerpo del taburete del mostrador.

(H1) x 2
bolt (M8x60mm)
perno

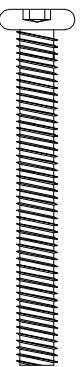

(H2) x 2
lock washer
arandela de
seguridad



(H3) x 2
flat washer
arandela plana



(H5) x 1
hex wrench
llave hexagonal

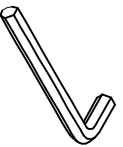

Note: Loosely attach bolts (don't securely tighten bolts) in this step.
Nota: Coloque los pernos sin apretar (no los apriete firmemente) en este paso.

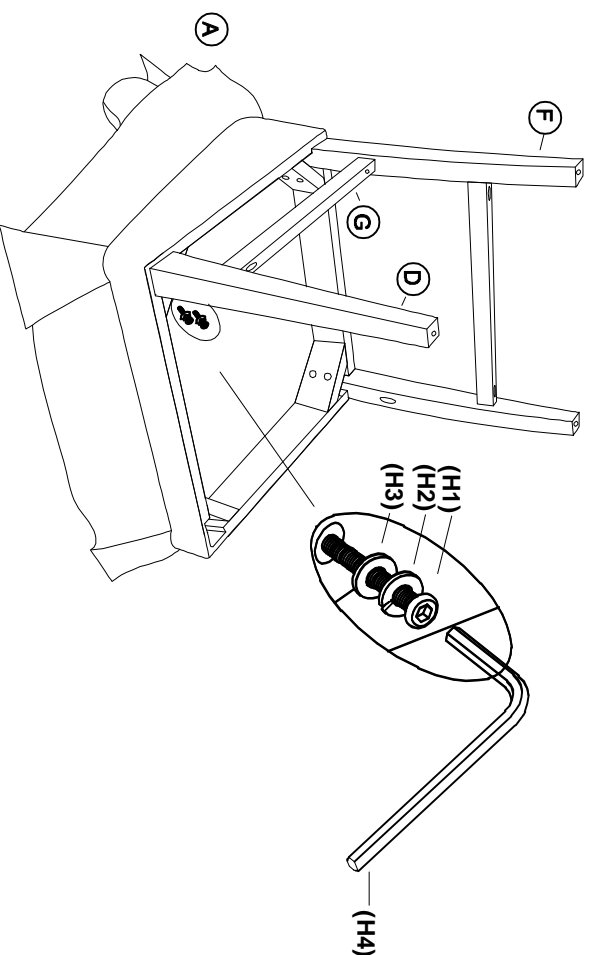

Attach side crossbar (G) to left back leg (F) and left front leg (D), loosely attach left front leg (D) to counter stool body (A), using bolt (H1), lock washer (H2), flat washer (H3) by hex wrench(H5).

Conecte la barra transversal lateral (G) a la pata trasera izquierda (F) y a la pata delantera izquierda (D), fije sin apretar la pata delantera izquierda (D) al cuerpo del taburete (A), usando el perno (H1) y la arandela de seguridad (H2), plana. arandela (H3) con una llave hexagonal (H5).

step 4: Attach right front leg to counter stool body, attach side crossbar and front crossbar to legs.

paso 4: Fije la pata delantera derecha al cuerpo del taburete del mostrador, fije la barra transversal lateral y la barra transversal delantera a las patas.

(H1) x 2
bolt (M8x60mm)
perno



(H2) x 2
lock washer
arandela de
seguridad



(H3) x 2
flat washer
arandela plana

(H5) x 1
hex wrench
llave hexagonal

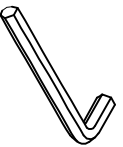

Loosly attach right front leg (C) to counter stool body (A), using bolt (H1), lock washer (H2), flat washer (H3) by hex wrench (H5), attach side crossbar (G) to right back leg (E) and right front leg (C), attach front crossbar (I) to right front leg (C) and left front leg (D).

Note: Loosely attach bolts (don't securely tighten bolts) in this step.
Nota: Coloque los pernos sin apretar (no los apriete firmemente) en este paso.

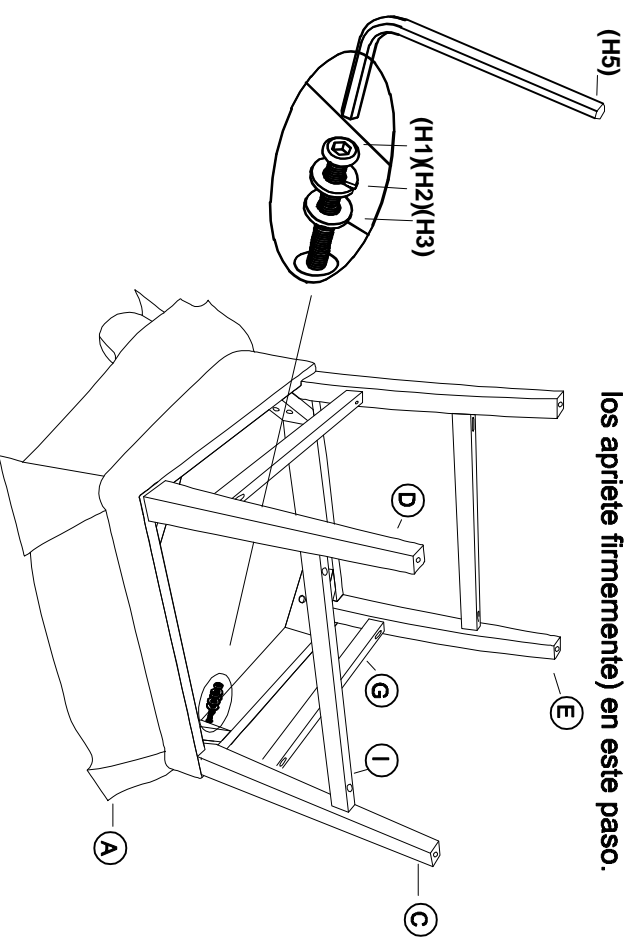

Fije sin apretar la pata delantera derecha (C) al cuerpo del taburete (A), usando el perno (H1), la arandela de seguridad (H2), la arandela plana (H3) con una llave hexagonal (H5), fije la barra transversal lateral (G) a la pata trasera derecha (E) y la pata delantera derecha (C), fije la barra transversal delantera (I) a la pata delantera derecha (C) y a la pata delantera izquierda (D).

step 5: Securely tighten all bolts.

paso 5: Apriete firmemente todos los pernos.

(H5) x 1
hex wrench
llave hexagonal

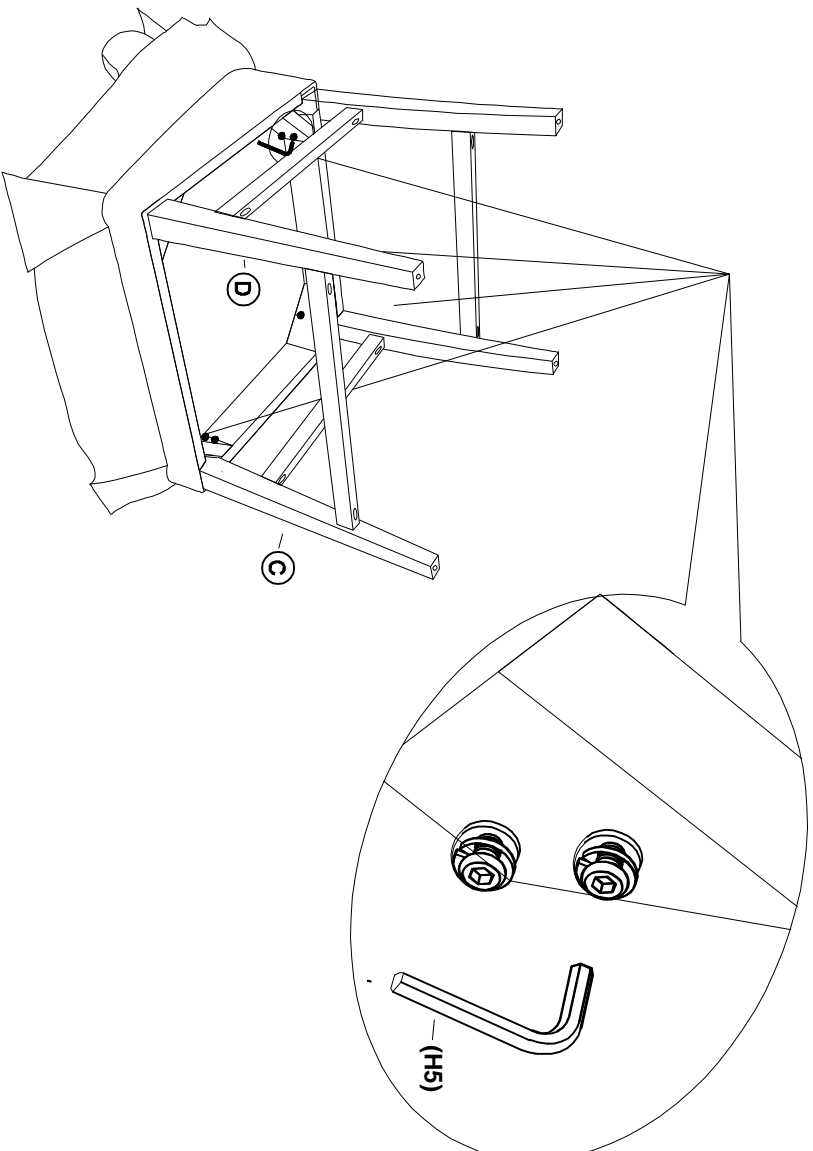
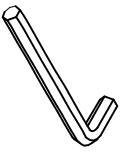

Securely tighten all bolts.

Apriete firmemente todos los pernos.

step 6: Securely tighten all screws to the crossbars.

paso 6: Apriete firmemente todos los tornillos a las barras transversales.

(H4) x 8
screw (M4x45mm)
tornillo

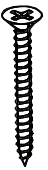

screw driver (not included)
destornillador (no incluidas)

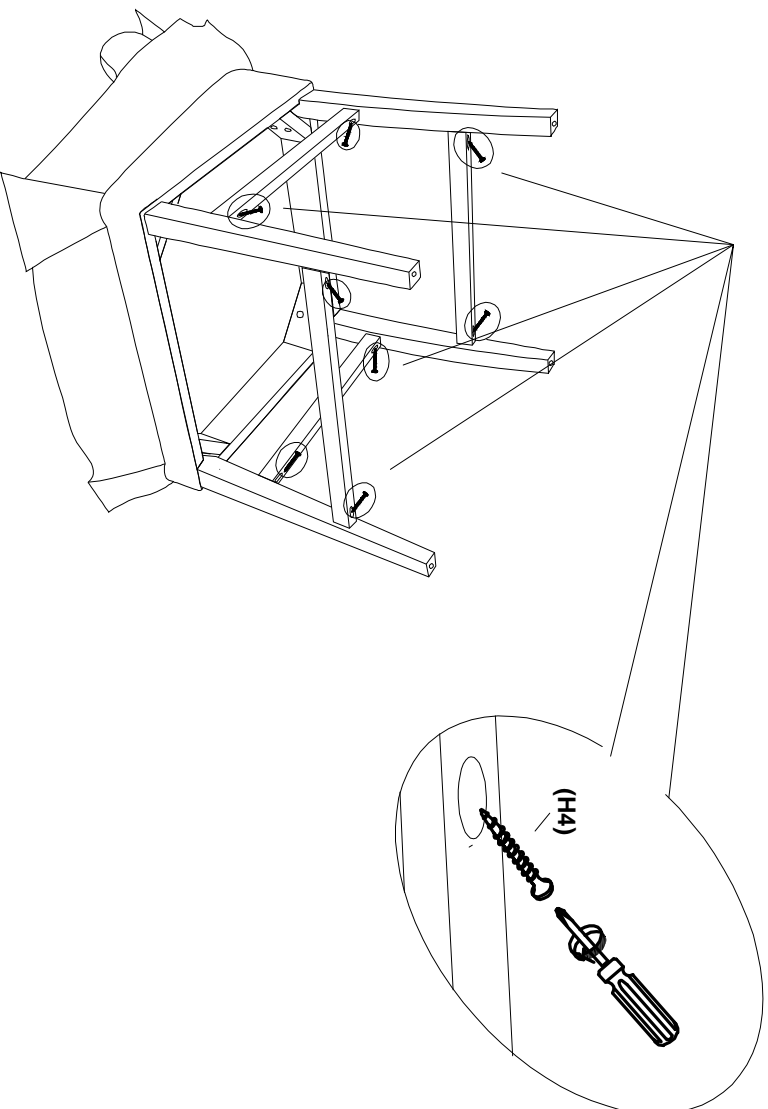

Attach front crossbar (I) to right front leg (C) and left front leg (D), using screw (H4) by screw driver, same way to attach all crossbar (G and J) to legs (C, D E and F), using screw by screw driver. Securely tighten all screws to the crossbars.

Fije la barra transversal delantera (I) a la pata delantera derecha (C) y a la pata delantera izquierda (D), usando un tornillo (H4) con un destornillador, de la misma manera para fijar todas las barras transversales (G y J) a las patas (C, D, E y F), usando tornillo por destornillador.

step 7 : Put seat cushion to seat body. **paso 7: Coloque el cojín del asiento en el cuerpo del asiento.**

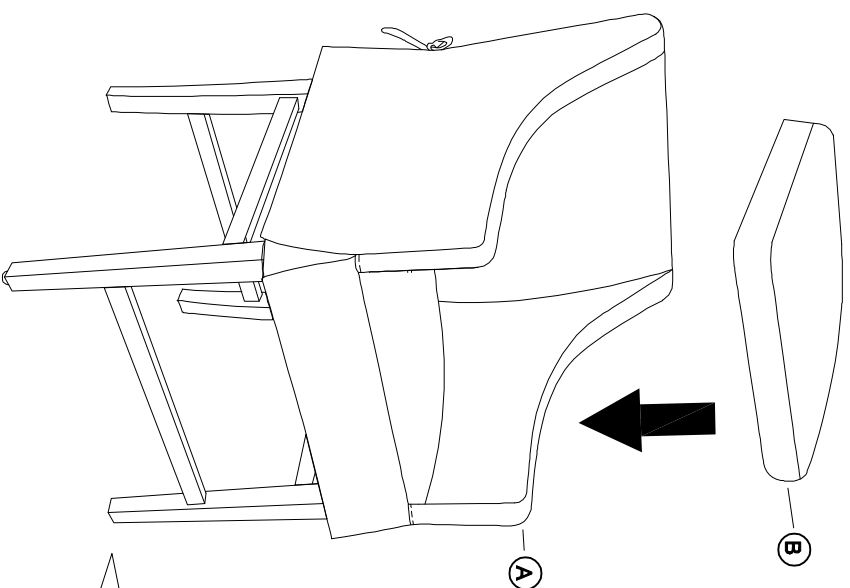

Note: Each leg can be adjusted with adjustable levelers.

Nota: Cada pata se puede ajustar con niveladores ajustables.

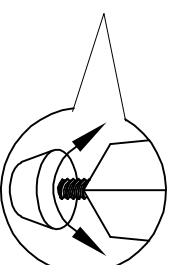

Put seat cushion (B) to seat body (A). Assembly is completed.
Additional note about safety : bolts may loosen during normal everyday use. They should be periodically inspected and re-tightened to prevent damage or injury. Always check to be sure that all hardwares are tightened securely.

Coloque el cojín del asiento (B) en el cuerpo del asiento (A). El montaje está completo.
Nota adicional sobre seguridad: los pernos pueden aflojarse durante el uso diario normal. Deben inspeccionarse y reapretarse periódicamente para evitar daños o lesiones. Siempre verifique para asegurarse de que todos los accesorios estén bien apretados.