

SHIP8, INC.

ATTN: ACCOUNTS PAYABLE
 45875 NORTHPORT LOOP EAST
 FREMONT, CA 94538
 US

AP.SHIP8@SHIP8.COM

ORDER FROM

101227

ATLAS COPCO COMPRESSORS LLC
 300 TECHNOLOGY CENTER WAY, SUITE 550
 ROCK HILL, SC 29730
 US

SHIP TO

SD2(2000),
 SHIP8, INC.
 ATTN: CHRISTINE JENKINS
 550 NORTHPORT PARKWAY
 PORT WENTWORTH, GA 31407
 US

PO No. 24060697 PO Date 06/21/2024 Page 1 OF 1

Buyer

Purchasing Dept

Terms

Net 30 Days

FOB

FOB Origin

Ship Via

Best possible

| Line No. | Vendor Item No. | Vendor Item Description | Qty Ordered | UOM | Unit Price | Extended Price |
|----------|-------------------------------|---------------------------------|-------------|------|------------|----------------|
| 1 | EQU011-COMPRESSOR MAINTENANCE | LABOR 7-8 | 1.00 | Each | | 310.00 |
| 2 | EQU011-COMPRESSOR MAINTENANCE | Parts 7-1-24 | 1.00 | Each | | 154.69 |
| 3 | EQU011-COMPRESSOR MAINTENANCE | Travel & Consumables 7-8 | 1.00 | Each | | 580.00 |

Total Extended Price =



Purchase Requisition Form

SHIP8 INC.

DATE 6/21/2024
 WHS LOCATION SD2
 DEPARTMENT Maintenance

SUPPLIER / VENDOR:**SHIP TO:**

NAME Atlas Copco
 ADDRESS _____
 CONTACT _____
 TEL NO. _____

NAME James Burford
 ADDRESS 550 Northport Parkway
Port Wentworth, GA 31407
 CONTACT James Burford
 TEL NO. _____

| | DESCRIPTION | UNIT PRICE | QTY | EXTENDED \$\$ | REMARKS/PURPOSE | CODING (ACCT USE ONLY) |
|------------------------|----------------------|------------|-----|--------------------|-----------------------------|------------------------|
| | Labor | \$ 310.00 | 1 | \$ 310.00 | Reference Quote # 155431555 | |
| | Parts | \$ 154.69 | 1 | \$ 154.69 | For SN: ITJ601057 | |
| | Travel & Consumables | \$ 580.00 | 1 | \$ 580.00 | | |
| | | | | \$ - | | |
| | | | | \$ - | | |
| | | | | \$ - | | |
| | | | | \$ - | | |
| | | | | \$ - | | |
| | | | | \$ - | | |
| | | | | \$ - | | |
| | | | | \$ - | | |
| | | | | \$ - | | |
| | | | | \$ - | | |
| | | | | \$ - | | |
| | | | | \$ - | | |
| | | | | \$ - | | |
| | | | | \$ - | | |
| | | | | \$ - | | |
| | | | | \$ - | | |
| | | | | \$ - | | |
| | | | | \$ - | | |
| | | | | \$ - | | |
| | | | | \$ - | | |
| ESTIMATED TOTAL | | | | \$ 1,044.69 | | |

Check box if attaching quote

REQUESTER SIGNATURE: _____
 WAREHOUSE DIRECTOR SIGNATURE: James Burford
 SHIP8 PRESIDENT SIGNATURE: _____
 E&E CONTROLLER SIGNATURE: _____
 IT AUTHORIZER (SOFTWARE & HARDWARE): _____

DATE: _____
 DATE: 6/21/2024
 DATE: _____
 DATE: _____
 DATE: _____

FOR OFFICE USE ONLY

ORDER DATE: _____ ORDERED BY: _____
 ETA DATE: _____ ORDERED AMOUNT: _____

PAYMENT METHOD: (Please check one)

OPEN ACCOUNT (VENDOR BILL) Provide REQ # to vendor for invoicing, submit approved requisition form to A/P for payment processing

COD / PREPAID Submit approved requisition form and vendor invoice to Controller for COD/prepaid check

COMPANY CREDIT CARD / CARD HOLDER Submit approved requisition form and receipt to Credit Card Holder

EMPLOYEE CREDIT CARD / CHECK Attach approved requisition form and receipt to employee's expense report for reimbursement.

Atlas Copco Compressor Services

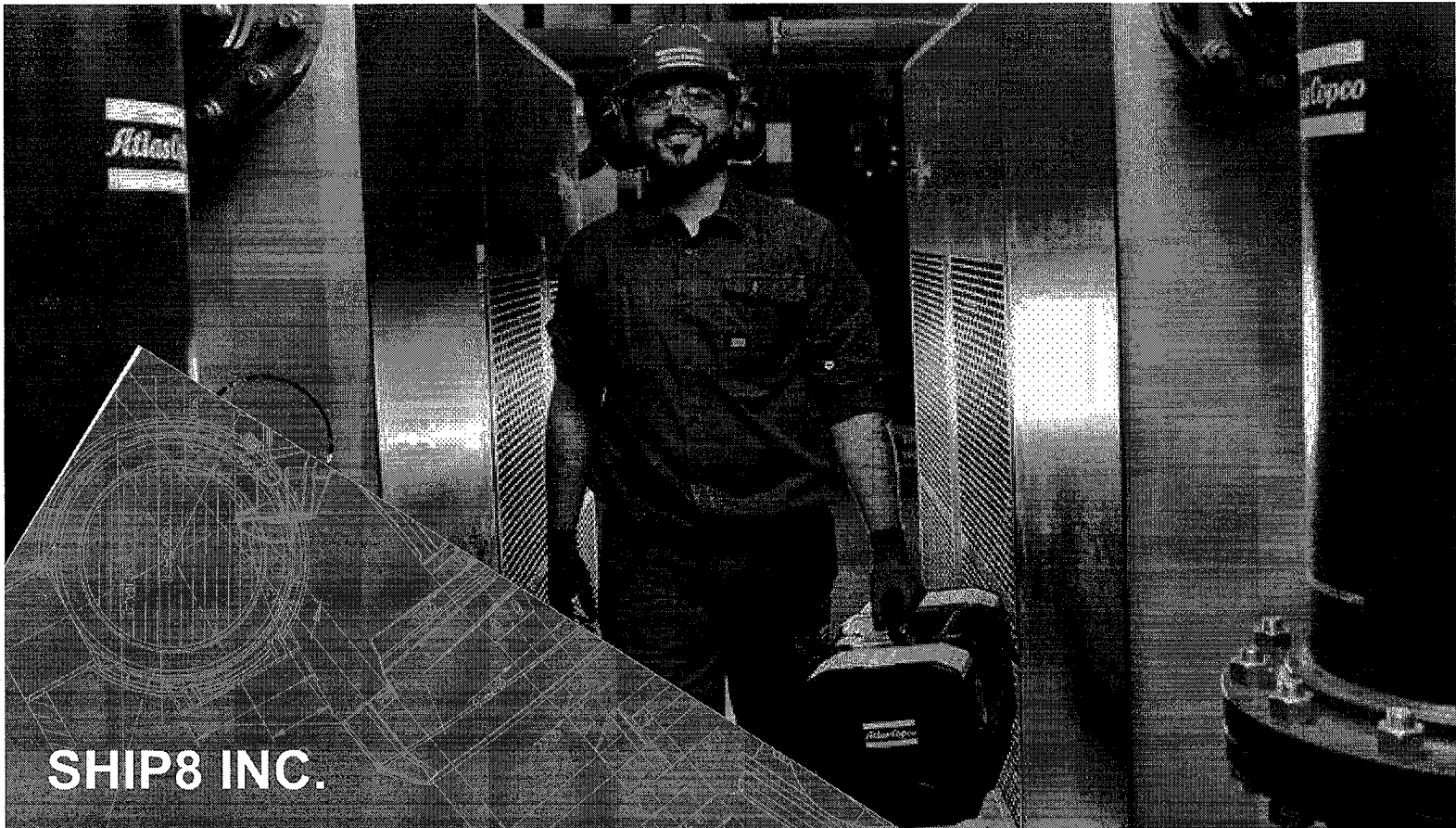

SHIP8 INC.

James Burford

Quote no: 155431555

Created: 06/20/24

Expiration: 07/20/24

Sustainable Productivity



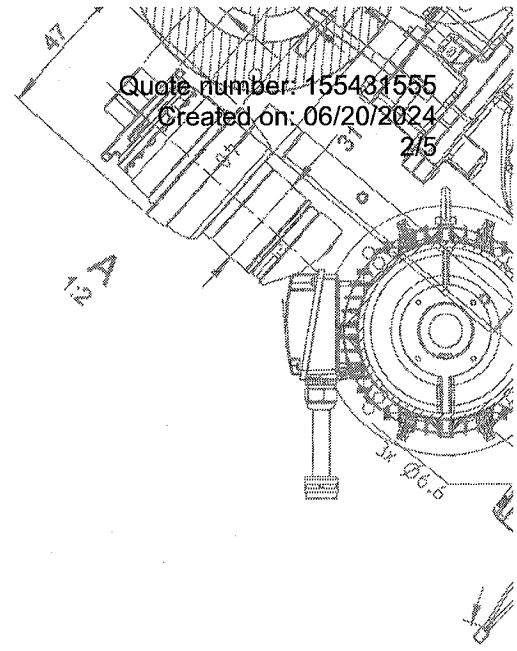

Fixed Price Quote #155431555

SHIP8 INC.

Attn to: James Burford

*NORTHPORT PKWY. 550
PORT WENTWORTH, 31407-9286*

Phone:

james.burford@SHIP8.COM

Dear James Burford,

We appreciate your interest in our Fixed Price Service.

Fixed Price services range from a simple inspection and diagnostics visit to a full overhaul of compressors and ancillary equipment. Fixed Prices are executed according to the manufacturer's recommendations, including all required parts/kits for the standard maintenance visit, labor, travel and accommodation, when needed, and a complete diagnostics report after each visit. Fixed price jobs are invoiced as one single price.

With Fixed Price services, the correct level of maintenance will be carried, according to parts wear needs, avoiding breakdowns. We only use Genuine Parts and Lubricants which will protect your investment and guarantee high performance levels.

Having the unit serviced by competent and experienced Atlas Copco service engineers is the best way to ensure maintenance is properly carried out and higher operational efficiency.

Atlas Copco is always available to provide you solutions for all of your compressed air needs, from generation to point of use, guaranteeing best performance from your whole system. Genuine parts and lubricants, specially developed for your compressor needs, are kept in stock and our service technicians are always up to date with our maintenance standards and will provide you with the best service in the market.

In case you need additional information on this quotation or any of our other service products, please feel free to contact me at any time.

Kind regards,

Josh Siegel

300 Technology Center Way
Rock Hill, NC 29730

Cell:
Fax:
joshua.siegel@atlascopco.com

Atlas Copco Compressors LLC

300 Technology Center Way
Ste. 550
Rock Hill, SC 29730, USA

Phone: +1 866-472-1013
www.atlascopco.com/service-usa
www.atlascopco.com/air-usa

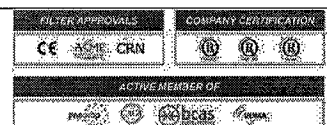

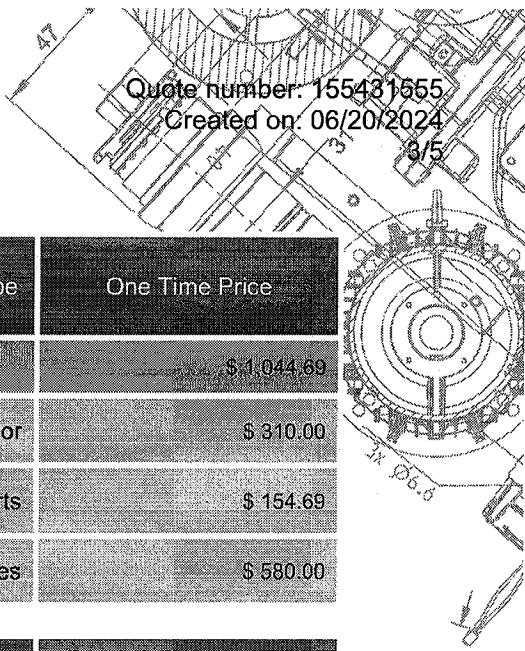

Quote number: 155431655
Created on: 06/20/2024

3/5

Pricing and Services Summary

| Machine Description | Serial Nr | Visits Type | Number of Oil Changes | Oil Type | One Time Price |
|------------------------------|-----------|-------------|-----------------------|----------|--------------------|
| G11 125psi FF(A4+) | ITJ601057 | FP | n/a | | \$ 1,044.69 |
| Total Labor | | | | | \$ 310.00 |
| Total Parts | | | | | \$ 154.69 |
| Total Travel and Consumables | | | | | \$ 580.00 |
| Total Price | | | | | \$ 1,044.69 |

Scope of Work: Rebuild unloader valve (oil leak) per technician recommendation.

Please notice that the consolidated one time price per machine will be shown on the invoice.

- Pricing does not include freight.
- Pricing does not include taxes
- Pricing applies to services performed during normal working hours, weekdays, from 8am – 5pm

Payment terms : Net 30 days after invoice date. Payment terms are subject to credit approval and may require a down payment.

Please ensure your PO reflects the following vendor address:

**Atlas Copco Compressors LLC
300 Technology Center Way, Suite 550
Rock Hill, SC 29730**

**If you can only have one address on file, please use the below remit-to address:
Atlas Copco Compressors LLC, DEPT CH 19511, Palatine, IL 60055-9511**

Atlas Copco Compressors LLC

300 Technology Center Way
Ste. 550
Rock Hill, SC 29730, USA

Phone: +1 866-472-1013
www.atlascopco.com/service-usa
www.atlascopco.com/air-usa

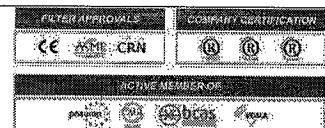

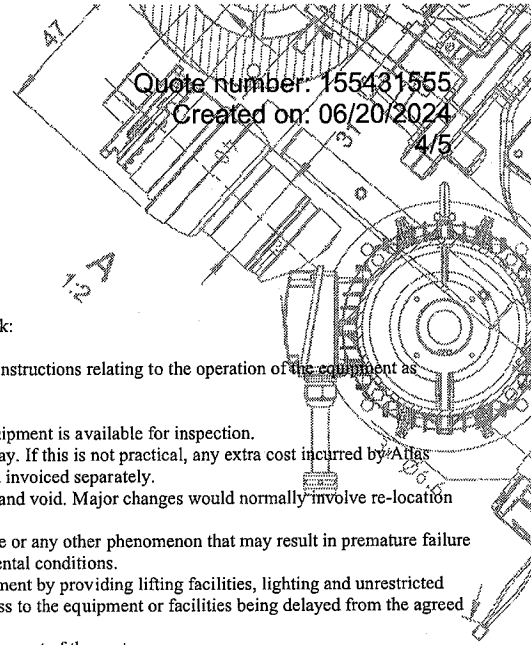

The following conditions apply

1. The Responsibilities and rights of the parties

- 1.1. The customer will ensure that:
 - 1.1.1. The routine maintenance of the equipment is carried out in accordance with Atlas Copco's instruction book;
 - 1.1.2. The equipment log book is filled in daily;
 - 1.1.3. At all times the equipment is kept in the environmental conditions recommended by Atlas Copco and the instructions relating to the operation of the equipment as advised by Atlas Copco from time to time are followed.
- 1.2. The customer will confirm to Atlas Copco that the instruction manual for the equipment is in his possession.
- 1.3. Atlas Copco will contact the customer before the planned time for the visit. The customer will then ensure the equipment is available for inspection.
- 1.4. Maintenance and Inspection will be carried out during normal working hours, 8.00 am - 5.00 pm, Monday to Friday. If this is not practical, any extra cost incurred by Atlas Copco in carrying out maintenance or inspection outside normal working hours will be borne by the customer and invoiced separately.
- 1.5. If any major changes occur in the operating or site conditions of the equipment, this agreement shall become null and void. Major changes would normally involve re-location of the unit, change of coolant or power.
- 1.6. The customer shall inform Atlas Copco immediately in the event of: malfunctions such as abnormal noise, leakage or any other phenomenon that may result in premature failure of the equipment; malfunctions of the hour meter; a planned transfer of the equipment or changes in its environmental conditions.
- 1.7. The customer will give necessary assistance to Atlas Copco in the performance of its obligations under this agreement by providing lifting facilities, lighting and unrestricted access to the equipment at the agreed time. Any costs and/or expenses incurred by Atlas Copco as a result of access to the equipment or facilities being delayed from the agreed time will be borne by the customer and invoiced separately by Atlas Copco.
- 1.8. The customer shall be responsible for a 25% restocking fee for any replacement parts order cancelled after the shipment of the parts.

2. Services

- 2.1. The price includes all costs of labor and material to perform a fixed price repair as described in the "Quotation" section excluding applicable taxes, except where under the terms of this agreement Atlas Copco is entitled to make an extra charge for these.
- 2.2. After visit a report on the condition of the equipment will be submitted to the customer by Atlas Copco.

3. Limitation and Termination

- 3.1. Atlas Copco shall not be obliged to inspect any equipment in the event of:
 - 3.1.1. Negligence by the customer in the performance of daily maintenance according to Clause 1.1;
 - 3.1.2. Any failure of the equipment caused by unforeseen circumstances including, but not limited to failure, interruption or out of specification provision of services to the equipment such as quality and/or quantity of cooling water, air, electrical power etc., accidental or willful damage to the equipment by the customer or a third party.
- 3.2. This agreement may be terminated by mutual agreement in writing of the parties.
- 3.3. Atlas Copco shall be entitled to terminate this agreement by notice in writing to the customer:
 - 3.3.1. In the circumstances referred to in Clauses 1.5 and 3.1;
 - 3.3.2. If the customer goes into liquidation or makes any voluntary arrangement with its creditors or becomes subject to an administration order or an encumbrance takes possession of or a receiver is appointed over any of the property or assets of the customer;
 - 3.3.3. If the customer ceases or threatens to cease to carry on business.
- 3.4. Neither party shall be liable to the other party for any indirect, consequential, incidental, special, punitive or exemplary damages or loss, of any kind, including, without limitation, any loss of business, lost profits or interruption of services (even if such party has been advised of the possibility of such damages or such damages could have been reasonably foreseen by such party). The total liability of the parties under this agreement after customer's payment of the purchase price for the product(s)/service(s) shall be limited to the amount of such purchase price as the exclusive remedy of the non-breaching party.
- 3.5. Temporary hire of equipment is not included to cover equipment outages unless otherwise agreed in writing by Atlas Copco.

4. Force Majeure

- 4.1. The delay or non-performance of any obligation under this agreement shall be excused if caused by an event beyond such party's reasonable control including but not limited to:
 - 4.1.1. Acts of God, restriction in the use of power, storm, lock out, strike, fire, civil commotion or civil unrest, act of war, compliance with the regulation or order of any governmental authority, quarantine, epidemic, or pandemic.

5. Guarantee

- 5.1. Atlas Copco warrants that the products provided are free from defects in material and workmanship and services are performed in a workmanlike manner. Atlas Copco standard equipment warranty applies and is available upon request.
- 5.2. THE FOREGOING WARRANTIES ARE EXCLUSIVE AND IN LIEU OF ALL OTHER WARRANTIES (WRITTEN, ORAL, IMPLIED, OR OTHERWISE), AND ALL OTHER WARRANTIES, INCLUDING BUT NOT LIMITED TO ANY IMPLIED WARRANTIES OF MERCHANTABILITY OR FITNESS FOR A PARTICULAR PURPOSE, ARE HEREBY EXPRESSLY DISCLAIMED.

6. Environmental Damages

- 6.1. The Environmental Management at any site on which Atlas Copco equipment is used is the responsibility of the Customer. In this regard Atlas Copco disclaims any responsibility for any infringement which occurs related to Acts, Rules or Regulations pertaining to environmental pollution aspects such as noise, atmospheric, water, sewer, dangerous goods, waste disposal etc.

7. General

- 7.1. If any term of this agreement is held by any court or other competent authority to be void or unenforceable in whole or in part the other terms of this agreement and the remainder of the affected term shall continue to be valid.
- 7.2. Any notice to be given by either party to the other under this agreement may be delivered by hand or sent by first class post to the other party at the address for that party shown in this agreement. Any notice delivered by hand shall be deemed to have been served on delivery and any notice sent by post shall be deemed to have been served within 48 hours after posting.
- 7.3. Any waiver by Atlas Copco of a breach of any terms of this agreement by the customer shall not be considered as a waiver of any subsequent breach of the same term or any other term.
- 7.4. Pricing does not include taxes and freight and will be added to the invoice.

8. SMARTLINK

The equipment may include a data monitoring service called SMARTLINK. The data received by Atlas Copco may be used by Atlas Copco and certain third party distributors and contractors for the purpose of increasing overall customer service. Atlas Copco will use commercially reasonable efforts to ensure that Purchaser's data is kept confidential. Purchaser acknowledges that the use of the SMARTLINK is provided "as is", that use of the service is entirely at Purchaser's risk, and that Atlas Copco may discontinue the SMARTLINK service at any time. Purchaser may request discontinuance of the SMARTLINK service at any time. SMARTLINK Terms and Conditions are available upon request.

Atlas Copco Compressors LLC

300 Technology Center Way
Ste. 550
Rock Hill, SC 29730, USA

Phone: +1 866-472-1013
www.atlascopco.com/service-usa
www.atlascopco.com/air-usa





Quote number: 155431555
Created on: 06/20/2024
5/5

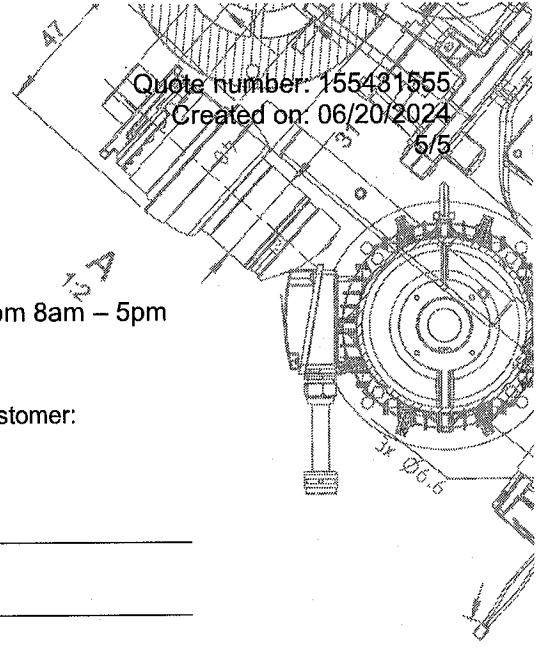

Pricing does not include freight.
Pricing does not include taxes

Pricing applies to services performed during normal working hours, weekdays, from 8am – 5pm

Signed for and on behalf of Atlas Copco:

Signed for and on behalf of the customer:

Signature:

Signature:

Joshua Siegel

Name: Josh Siegel

Name: James Burford

Position:

Position:

Date: 06/20/2024

Date: 06/20/2024

Customer# 106136440

PO#

Atlas Copco Compressors LLC

300 Technology Center Way
Ste. 550
Rock Hill, SC 29730, USA

Phone: +1 866-472-1013
www.atlascopco.com/service-usa
www.atlascopco.com/air-usa



Date 26/Jun/2024

Page 1 of 1

Ship to
Ship8 Inc.Northport Pkwy. 550
314079286 Port Wentworth
GA USA**Seller**Atlas Copco Compressors
300 Technology Center Drive
29730 Rock Hill
SC USA**Customer Reference:** 4512995694
Customer PO: PO: 24060697
Shipping Marks:**Contract nr:**
Serial nr: ITJ601057
Service order nr: 407372033**ODO:** 2964983
Terms of delivery: CPT

HU: 2003976669

| Case number | Type of pack | Weight | Dimensions | Tracking nr forwarder |
|-------------|--------------|---------|------------------------|-----------------------|
| 2003976669 | PL-ENV-0006 | 0.10 LB | 9.53 x 13.78 x 2.01 IN | 1Z8725FR0399641861 |

| Item | Material | Material Description | Quantity | UoM |
|------|------------|-------------------------|----------|-----|
| 10 | 2200900961 | KIT SPARES UNLOADER C55 | 1 | PC |

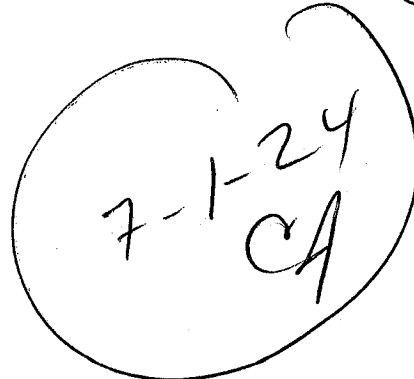
Track your order:**Shipper**
North American Service Center
11313 Steele Creek Road
Charlotte, NC 28273-3713

> Favorites

▾ Folders

📁 Inbox 457

✍ Drafts

📁 Sent Items 5

🗑 Deleted Items 361

📁 Junk Email 4

📁 Archive

📄 Notes

📁 Conversation History

Create new folder

🔍 Search Folders

Go to new Groups

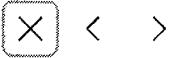

Atlas Copco Visit Report for SHIP8 INC., G11FF 125 TRI-V/60 TM71 API, ITJ601057 ▾

JB

😊 ↶ Reply ↶ Reply all ↷ Forward 🗑 📄

To: Christine Jenkins; sav.maint.n Mon 7/8/2024 12:26 PM

📄 VR_US10_000407372033_ITJ6... ▾
73 KB

This PO is completed - 24060697

Handwritten note in a circle: 7-8-24 CA



SHIP8 INC.

James Burford
Regional Facilities Director
311 International Trade Pkwy
Port Wentworth, GA 31407

C:912.507.7881



Visit Report

Report date: Jul 03, 2024

SHIP8 INC.
NORTHPORT PKWY. 550
31407-9286 PORT WENTWORTH GA
Contact: JAMES BURFORD

Work Comments

07/03/24-AG - Onsite for work on unit. change unloader valve kit, clean unit in and out for oil leak, check oil level, check for air and oil leak. compressor is unloading and loading out of set points. compressor is out of service waiting for parts

Time Confirmation

| Date | Service Engineer |
|--------------|------------------|
| Jul 03, 2024 | Alexis Gonzalez |
| Jul 03, 2024 | Alexis Gonzalez |
| Jul 03, 2024 | Alexis Gonzalez |

Equipment

| | | | |
|-----------------------|-----------------------------|-------------------------|--------------|
| Equipment: | G11FF 125 TRI-V/60 TM71 API | Visit date: | Jul 03, 2024 |
| Serial Number: | ITJ601057 | Order Number: | 407372033 |
| Running Hours: | 4088 hours | PO number: | PO: 24060697 |
| Load Hours: | hours | Contract Number: | |

Work Done

| Operations | Comments |
|------------------------------------|----------|
| ✓ Check oil level | - |
| ✓ Check all dryer components | - |
| ✓ Check for air leaks (dryer) | - |
| ✓ Drain Condensate in Air receiver | - |
| ✓ Check belt drive | - |
| ✓ Check and clean oilcooler | - |
| ✓ Clean condenser (FF units) | - |
| ✓ Test safety valve | - |
| ✓ Check electrical components | - |
| ✓ Check Shutdown switches | - |

Material Confirmation

| Part Number | Part Description | Quantity | unit |
|-------------|-------------------------|----------|------|
| 2200900961 | KIT SPARES UNLOADER C55 | 1 | |

Measurement Points

| Counter | Reading after service | Before service | From last visit on |
|------------------------------|-----------------------|----------------|---------------------|
| Actual running hours (Total) | 4088 OPH | | 2024-06-17 4087 OPH |
| Working pressure PSI | 122 PSI | | 2024-06-17 122 PSI |
| Pressure dewpoint | 38 FA | | 2022-12-20 38 FA |

AUTHORIZATION TO CARRY OUT WORK WITH/WITHOUT AN ORDER NO.

Notes Customer will agree to supply Atlas Copco with a valid order number or payment for non-account holders for actual time spend, travelling and parts used during the breakdown intervention by next working day.

Customer Confirmation

Signed by JAMES BURFORD at 7/3/2024, 5:13:03 PM
(Being duly authorised to sign on behalf of the customer)

Service Engineer Confirmation

Signed by Alexis Gonzalez at 7/3/2024, 5:13:18 PM

Atlas Copco Compressors, LLC

Corporate Office
300 Technology Center Way, Suite 550
Rock Hill, SC 29730

www.atlascopco.us

Corporate Tel: 803-817-7000

| | | | | |
|---------------------|--------------------|---------------------|---------------------------|------------|
| Customer No. | Invoice No. | Invoice Date | Purchase Order No. | 1/2 |
| 4000369649 | 1124069808 | 07/10/2024 | PO: 24060697 | |

Atlas Copco Compressors LLC
300 Technology Center Way Ste. 550, Rock Hill, SC 29730

SHIP8 INC.
45875 NORTPORT LOOP EAST
FREMONT, CA 94538

Visit Address

SHIP8 INC.
550 NORTHPORT PKWY.
PORT WENTWORTH, GA 31407-9286

Customer's Address

SHIP8 INC.
550 NORTHPORT PKWY.
PORT WENTWORTH, GA 31407-9286

Payer : SHIP8 INC., 45875 NORTPORT LOOP EAST, FREMONT, CA 94538

Serv. Order No. : 407372033
Serv. Exec. Date : 07/03/2024

Contact Reference

Contact : ZS8 North FL
Tel No. : 866-567-0179
E-mail : cts.south.
region@atlascopco.com

Customer Information

Contact : ACCOUNTS PAYABLE
Tel No. : 510 490 9788
E-mail : AP.SHIP8@SHIP8.COM

Dear JAMES BURFORD

This is the invoice for the quoted services of your G11FF 125 TRI-V/60 TM71 API with serial number ITJ601057

Thank you for your business and please do contact us in case there are any issues with the machine.

| Pos. | Material ID | Description | Qty | UOM | Price/Unit | Disc. | Total Net Price | |
|------------|-------------|--|-------------|-----|-------------------------------|-------|-----------------|--------|
| Equipment | | : 111788797 | Description | | : G11FF 125 TRI-V/60 TM71 API | | | |
| Serial No. | | : ITJ601057 | | | | | | 154.69 |
| 10 | | FIXED PRICE PARTS LABOR AND EXPENSE | | | | | | 890.00 |

| | | |
|--------------------|-----------------|------------|
| Subtotal | 1,044.69 | USD |
| Freight (Normal) | 14.71 | USD |
| Net / Tax base | 1,059.40 | USD |
| State Tax:GA | 6.78 | USD |
| County Tax: | 5.08 | USD |
| Total | 1,071.26 | USD |

Atlas Copco Compressors LLC

<http://www.atlascopco.com/ACCSalesTerms>

15045 Lee Road
Houston, TX 77032

Telephone: (281) 590-7500
Fax: (281) 590-5611
<https://www.atlascopco.com/en-us>

Federal Tax ID: 04-2700546
Remit To:
Atlas Copco Compressors LLC
DEPT CH 19511
Palatine, IL 60055-9511

ACH Payments: Nordea Bank Finland PLC
1211 Avenue of the Americas, 23rd Floor
New York, NY 10036
ABA # 026010786
Account # 7145273001
SWIFT # NDEAUS3N

| | | | | |
|---------------------|--------------------|---------------------|---------------------------|------------|
| Customer No. | Invoice No. | Invoice Date | Purchase Order No. | 2/2 |
| 4000369649 | 1124069808 | 07/10/2024 | PO: 24060697 | |

Payment terms : Net 30 Days
Payment Due Date : 08/09/2024
Delivery terms : FOB
Delivery freight charges

Remit To:
Atlas Copco Compressors LLC
DEPT CH 19511
Palatine, IL 60055-9511

| | | | | |
|---------------------|-------------------|--------------------|--------------------|-----|
| Delivery | 830475966 | Delivery Date | 06/26/2024 | |
| Forwarder Name UPSN | | | | |
| Case Number | 2003976669 | Tracking Number | 1Z8725FR0399641861 | |
| Material Number | Order Number | Customer Po Number | Qty | UOM |
| 2200900961 | 407372033 | PO: 24060697 | 1.00 | PC |