

MADISONPARK® ASSEMBLY INSTRUCTIONS

Description: Simon Counter Stool









Important safety instructions:

- Please read carefully all instructions before assembly.
- For your safety and ease, assembly by two or more adults is recommended.
- Keep instructions for future use.

Pre-assembly:



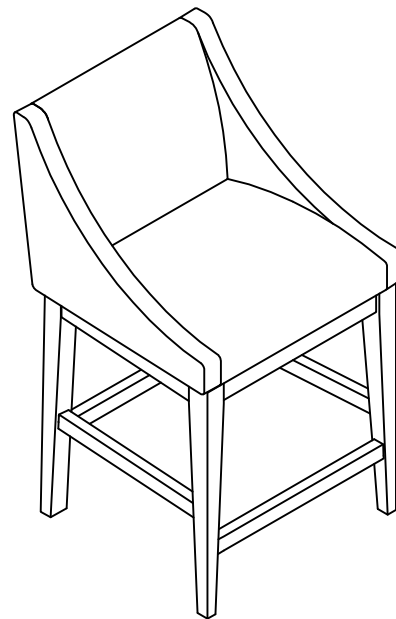

- Do not discard any content until assembly is complete to avoid accidentally discarding small parts or hardware.
- Take out all parts and hardware from box.

Parts List

Item	Description	QTY
P1	Chair Top 	1
P2	Back Left Leg 	1
P3	Back Right Leg 	1
P4	Front Right leg 	1
P5	Front Left leg 	1
P6	Back stretcher 	1
P7	Front Stretcher 	1
P8	Right Side Stretcher 	1
P9	Left Side Stretcher 	1



Hardware List

Item	Description	QTY
H1	Bolts Ø1/4"*2-1/4"L 	8
H2	Lock Washers 1/4" 	8
H3	Flat Washers 1/4" 	8
H4	Allen Wrench 1/4" 	1
H5	Screws #8*1-1/2" 	8

DISCLAIMER:

WHEN PROPERLY ASSEMBLED, THIS ITEM IS SAFE FOR INTENDED USE. SELLER IS NOT LIABLE FOR ANY DAMAGES RESULTING FROM ITEM BEING IMPROPERLY ASSEMBLED AFTER PURCHASE.



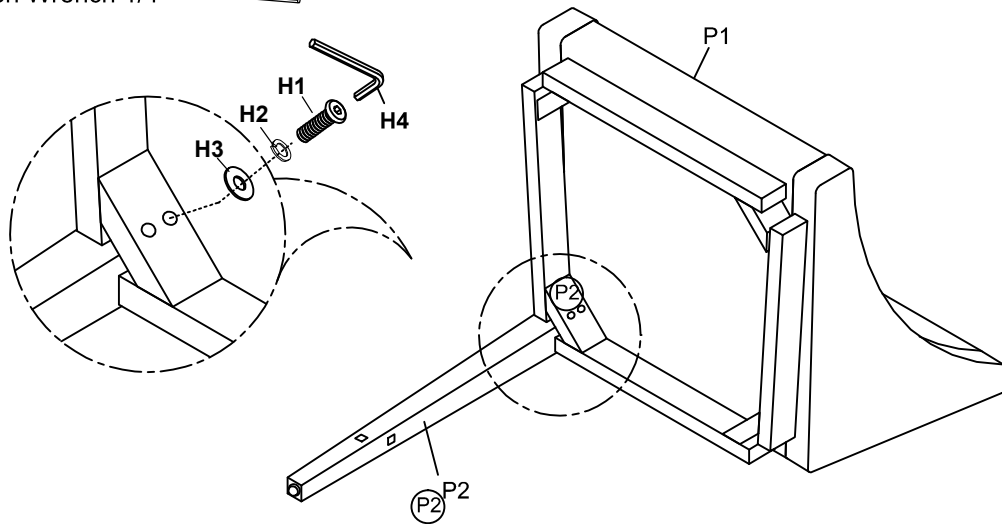

Assembly Procedures:

Step 1. Assemble the stool on a flat, soft surface such as a carpet or cloth to prevent scratching the finish. **Loosely** attach the back left leg (P2) to chair top (P1) following the label "P2" on the back left leg (P2) and chair top (P1) accordingly as shown below.

- (H1)x2 Bolts $\text{\O}1/4'' \times 2-1/4''\text{L}$ 
- (H2)x2 Lock Washers 1/4" 
- (H3)x2 Flat Washers 1/4" 
- (H4)x1 Allen Wrench 1/4" 





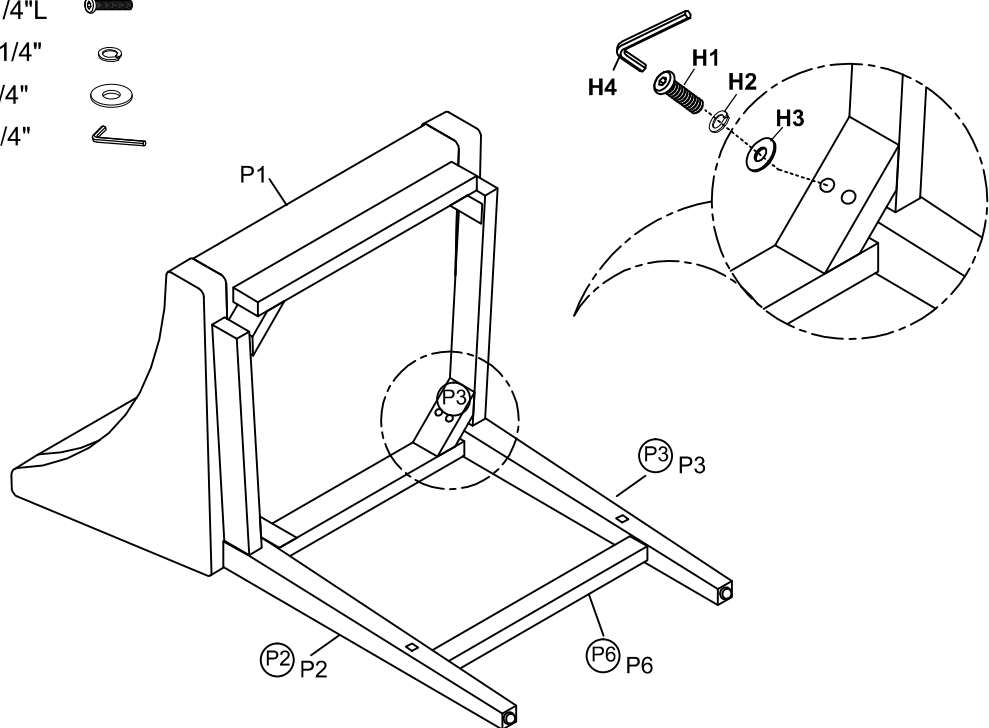

Step 2. Insert the back stretcher (P6) to back left leg (P2) following the label "P6" on back stretcher (P6) accordingly. **Loosely** attach the back right leg (P3) to the bottom of chair top (P1) and the back stretcher (P6) following the label "P3" on back right leg (P3) and the bottom of seat cushion (P1) accordingly as shown below.

- (H1)x2 Bolts $\text{\O}1/4'' \times 2-1/4''\text{L}$ 
- (H2)x2 Lock Washers 1/4" 
- (H3)x2 Flat Washers 1/4" 
- (H4)x1 Allen Wrench 1/4" 





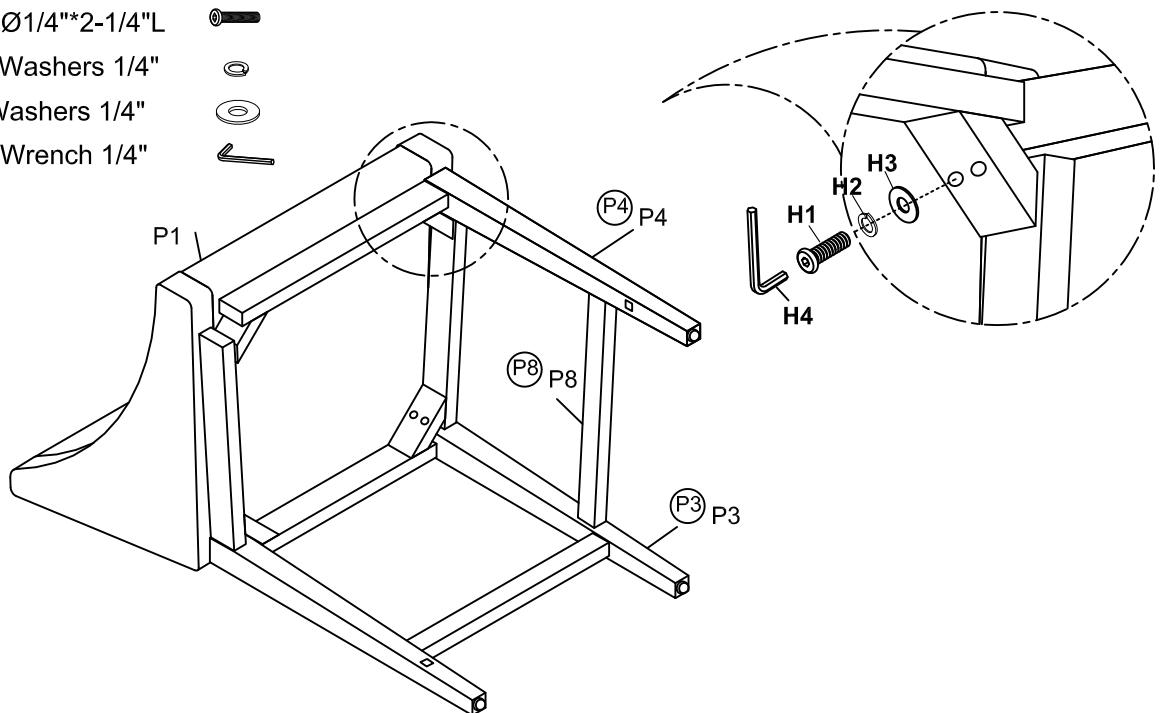

Step 3. Insert the right side stretcher (P8) between the back right leg (P3) and front right leg (P4) following the label "P8" "P4" and "P3" on each part accordingly. **Loosely** attach front right leg (P4) to the bottom of seat cushion (P1) using bolts (H1), lock washers (H2) and flat washers (H3) as shown below.

- (H1)x2 Bolts Ø1/4"*2-1/4"L 
- (H2)x2 Lock Washers 1/4" 
- (H3)x2 Flat Washers 1/4" 
- (H4)x1 Allen Wrench 1/4" 



Step 4.

- 1) Insert front stretcher (P7) between front right leg (P4) and front left leg (P5), and insert left side stretcher (P9) between front left leg (P5) and the back left leg (P2) following "P7", "P9" on each part accordingly, then **loosely** attach last leg (P5) to bottom of seat cushion (P1) as shown below.
- 2) Tighten screws (H5) through the stretchers (P6, P7, P8, P9) to each leg with screw driver (not provided).
- 3) Make sure the stool is level and securely tighten all bolts by Allen wrench (H4).
- 4) Assembly is complete. **Failure to follow these instructions may cause the bolts to misalign during assembly.**

- (H1)x2 Bolts Ø1/4"*2-1/4"L 
- (H2)x2 Lock Washers 1/4" 
- (H3)x2 Flat Washers 1/4" 
- (H4)x1 Allen Wrench 1/4" 
- (H5)x8 Screws #8*1-1/2" 

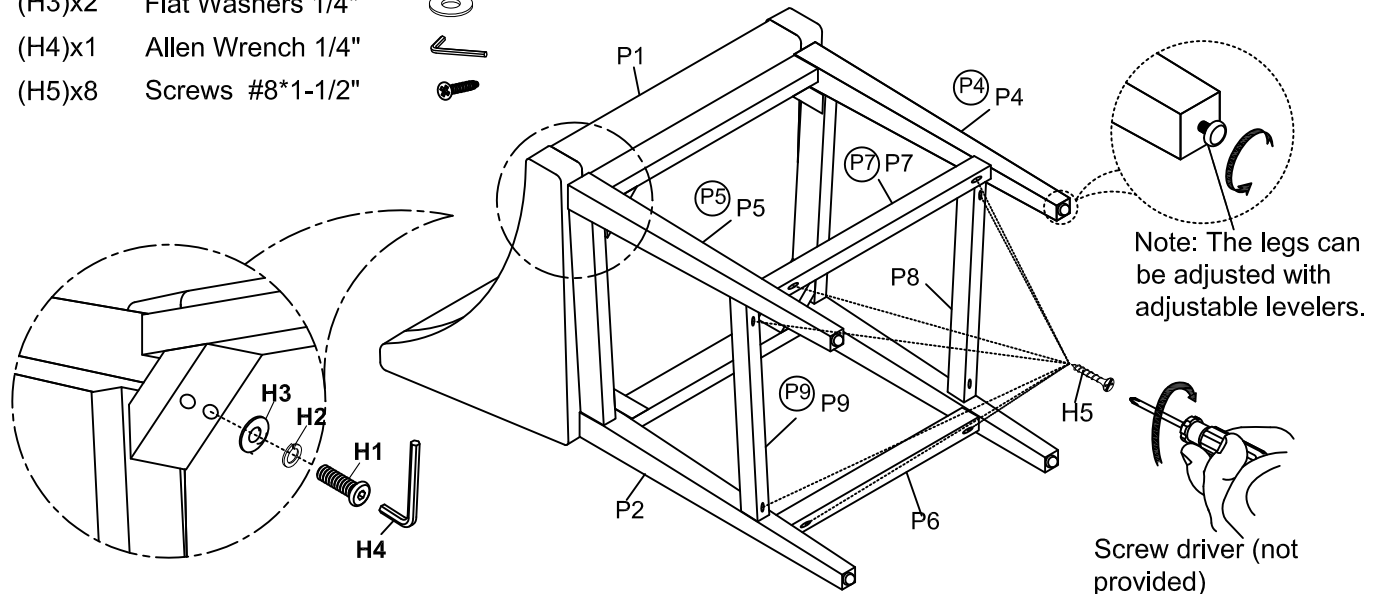

ADDITIONAL NOTE ABOUT SAFETY:
BOLTS MAY LOOSEN DURING NORMAL EVERYDAY USE.
THEY SHOULD BE INSPECTED AT LEAST EVERY 3 MONTHS AND RE-TIGHTENED AS NEEDED TO PREVENT DAMAGE OR INJURY,
AND ENSURE STABILITY.

Thank you for your purchase