

# ASSEMBLY INSTRUCTIONS

Description: Marian Counter Stool





**Important safety instructions :**

- Please read carefully all instructions before assembly.
- For your safety and ease, assembly by two or more adults is recommended.
- Keep instructions for future use.

**Pre-assembly:**



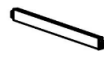

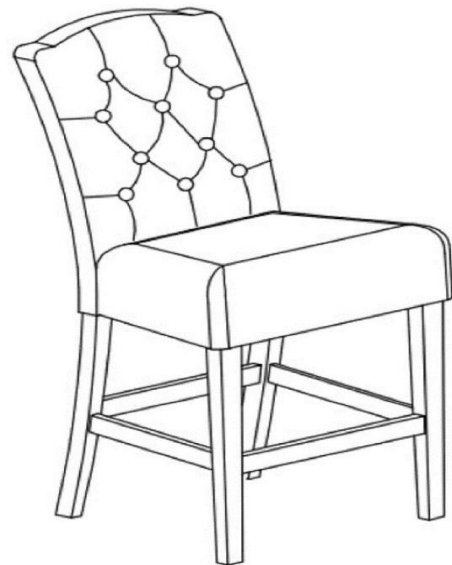

- Do not discard any contents until assembly is complete to avoid accidentally discarding small parts or hardware.
- Remove all parts and hardware from box along with any plastic protective packaging.

Parts List

Item	Description		QTY
P1	Chair Back		1
P2	Seat Cushion		1
P3	Side Stretcher		2
P4	Front Stretcher		1
P5	Front Legs		2



Hardware List

Item	Description		QTY
H1	Long Bolts $\varnothing 5/16"$ x 3 1/2"		4
H2	Short Bolts $\varnothing 5/16"$ x 2"		7
H3	Spring Washers 5/16"		11
H4	Flat Washers 5/16"		11
H5	Allen Wrench 5/16"		1
H6	Screw #8 X 1-3/4"		6
H7	Screwdriver		** Not Provided

**DISCLAIMER :**

**WHEN PROPERLY ASSEMBLED, THIS ITEM IS SAFE FOR INTENDED USE.  
SELLER IS NOT LIABLE FOR ANY DAMAGES RESULTING FROM ITEM BEING IMPROPERLY ASSEMBLED AFTER PURCHASE.**

**Assembly Procedures:**

Step 1.

1) Assemble the stool on a flat, soft surface such as carpet or cloth to prevent scratching the finish.

2) Attach the Seat Cushion (P2) to Chair Back (P1) using Allen Wrench (H5), Short Bolts (H2), Spring Washer (H3), and Flat Washers (H4).

Do not fully tighten at this step .

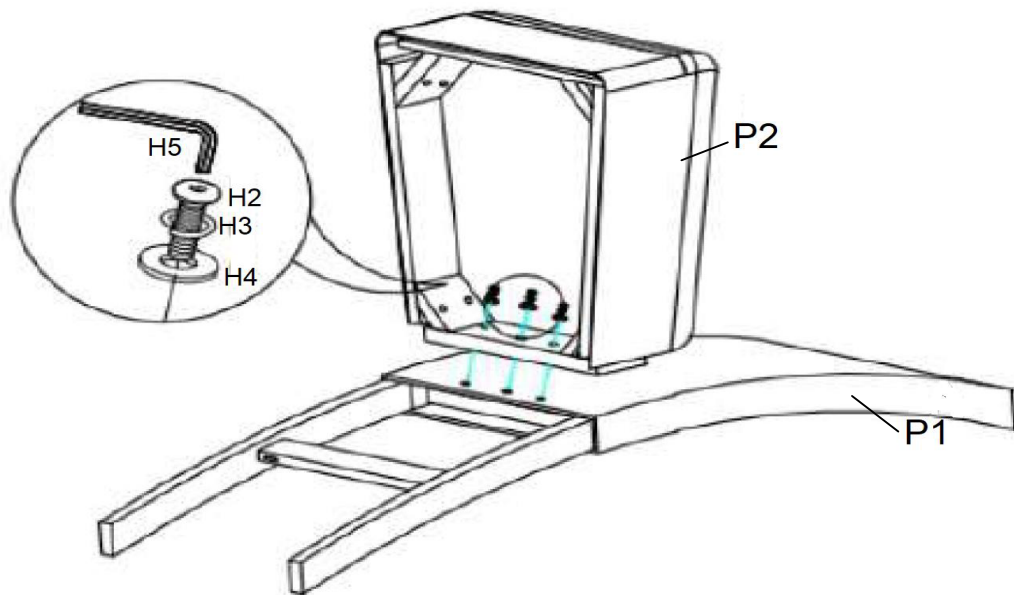

Step 2 .

Secure the corner blocks of Seat Cushion (P2) to the legs of Chair Back (P1) with Allen Wrench (H5), Long Bolts (H1), Spring Washers (H3) and Flat Washers (H4).

Do not fully tighten at this step .

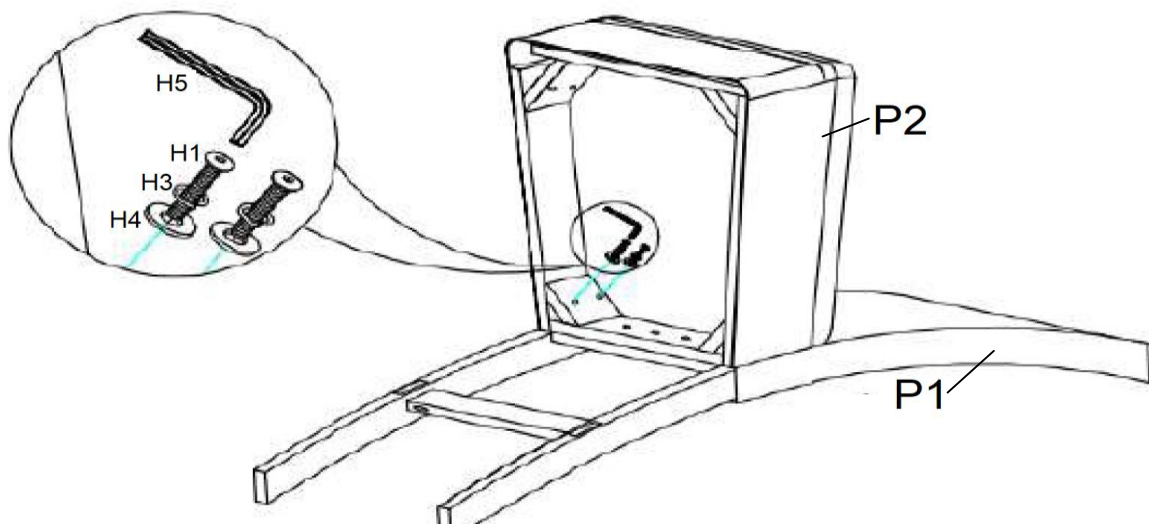

**Step 3:**

- 1) Attach the Side Stretcher (P3) to the right leg of Chair Back (P1) at the pre-drilled hole of the right leg of Chair Back (P1) and the front end of Leg (P5).
  - 2) Loosely attach one of the Front Leg (P5) to the right-side bottom of Seat Cushion (P2) and Side Stretcher (P3) using Allen Wrench (H5), Short Bolts (H2), Spring Washers (H3) and Flat Washers (H4).
- Do not fully tighten at this step.

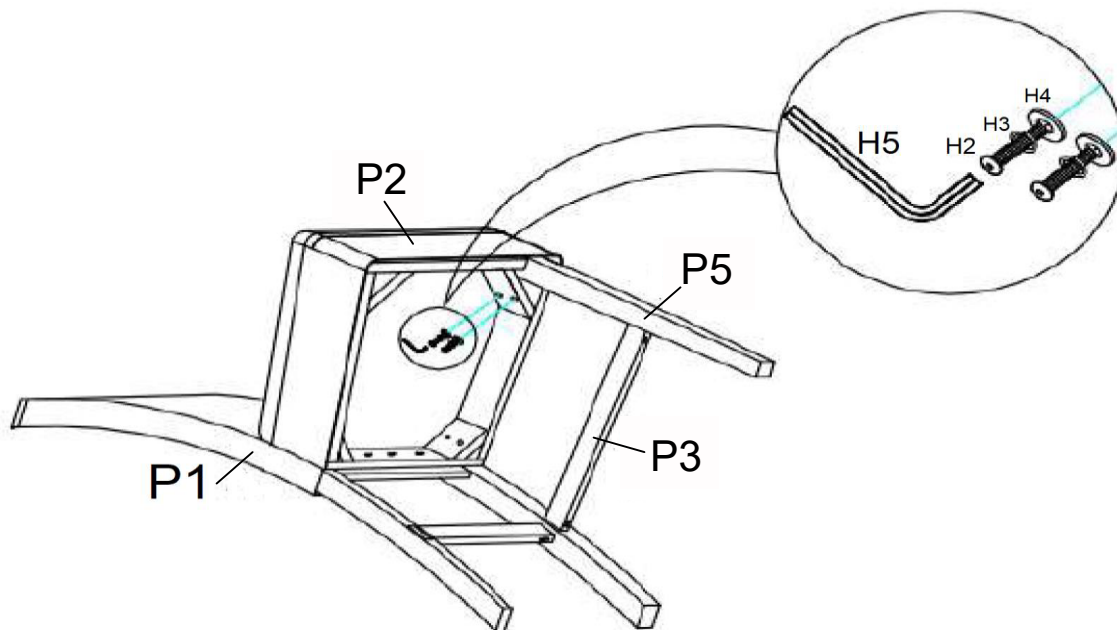

- 1) Attach the Side Stretcher (P3) to the right leg of Chair Back (P1) at the pre-drilled hole of the left leg of Chair Back (P1) and the front end of Leg (P5).
- 2) Loosely attach another Front Leg (P5) to the left-side bottom of Seat Cushion (P2) and Side Stretcher (P3) using Allen Wrench (H5), Short Bolts (H2), Spring Washers (H3) and Flat Washers (H4).
- 3) Attach the Front Stretcher (P4) between the Front Legs (P5)
- 4) Fully tighten all Bolts (H1, H2)
- 5) Secure and fully tighten with screwdriver (H7) for all Screws (H6) at the Stretcher (P3, P4).

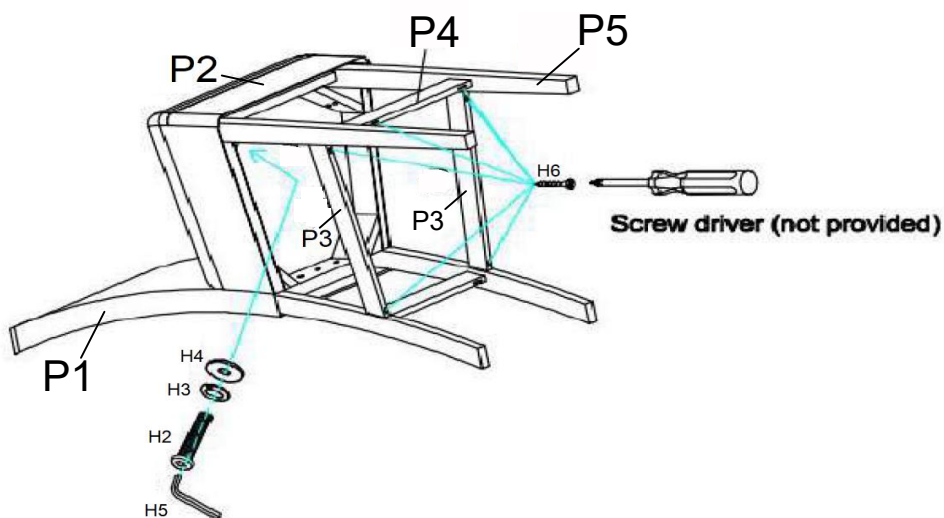

**ADDITIONAL NOTE ABOUT SAFETY :**  
BOLTS MAY LOOSEN DURING NORMAL EVERYDAY USE.  
THEY SHOULD BE INSPECTED AT LEAST EVERY 3 MONTHS AND RE-TIGHTENED AS NEEDED TO PREVENT DAMAGE OR INJURY AND ENSURE STABILITY.

THANK YOU FOR YOUR PURCHASE