



Important safety instructions:

- Please read carefully all instructions before assembly.
- For your safety and ease, assembly by two or more adults is recommended.
- Keep instructions for future use.

Pre-assembly:



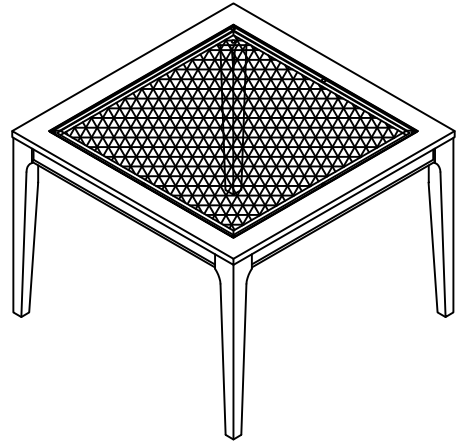

- Do not discard any content until assembly is complete to avoid accidentally discarding small parts or hardware.
- Take out all parts and hardware from box.

Parts List

Item	Description	QTY
P1	Table Top Frame 	1
P2	Legs 	4
P3	Glass 	1



Hardware List





Item	Description	QTY
H1	Bolts $\phi 5/16$ "x 2-1/2"L 	8
H2	Lock Washers 5/16" 	8
H3	Flat Washers 5/16" 	8
H4	Allen Wrench 5/16" 	1
H5	Plastic Pad $\phi 12$ *4mm 	8

DISCLAIMER:

WHEN PROPERLY ASSEMBLED, THIS ITEM IS SAFE FOR INTENDED USE. SELLER IS NOT LIABLE FOR ANY DAMAGES RESULTING FROM ITEM BEING IMPROPERLY ASSEMBLED AFTER PURCHASE.

Assembly Procedures:

Step 1: Assemble the table on a flat, soft surface such as a carpet or cloth to prevent scratching the finish. Attach the legs (P2) to the table top frame (P1) as shown below.

- (H1)x8 Bolts $\phi 5/16$ "*2-1/2"L 
- (H2)x8 Lock Washers $\phi 5/16$ 
- (H3)x8 Flat Washers $\phi 5/16$ 
- (H4)x1 Allen Wrench $\phi 5/16$ 

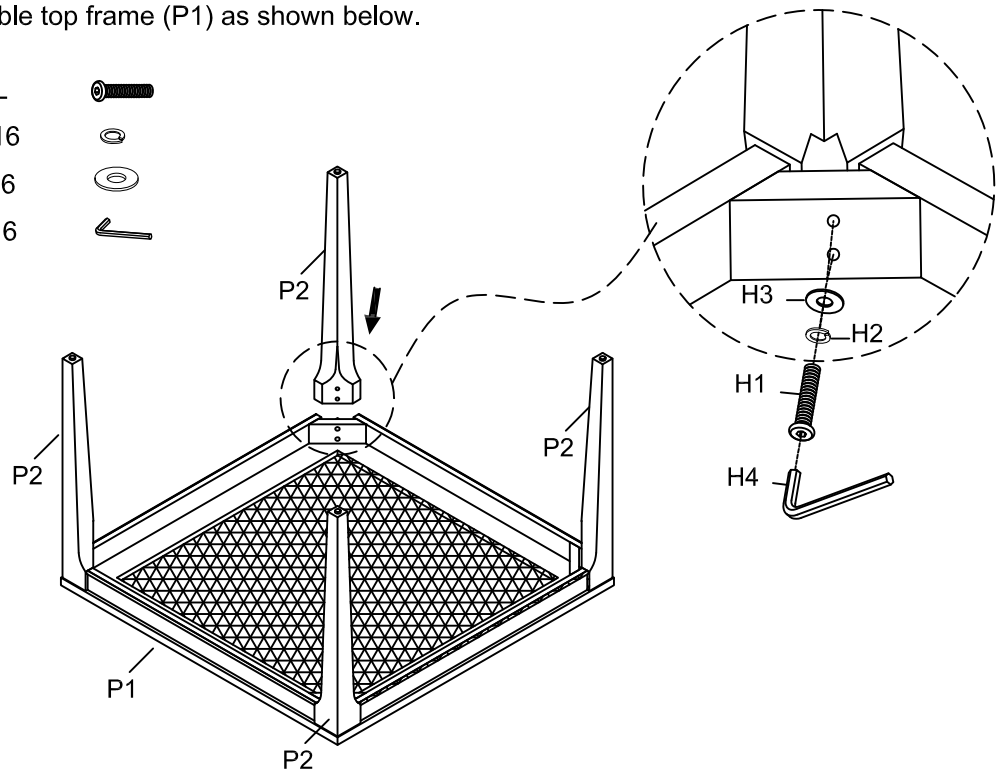

Step 2. Securely tighten all bolts with Allen wrench(H4). Turn the assembled table to an upright position, make sure the table is level, aligned properly. Place the plastic pad (H5) on the top of table top frame (P1) as shown below.

(H5)x8 Plastic Pad $\varnothing 12*4\text{mm}$ 

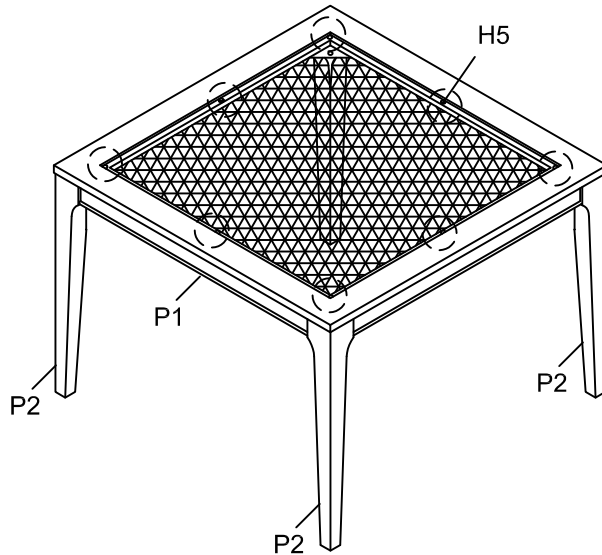

Step 3. Gently lay the glass (P3) on the table top frame (P1) as shown. Assembly is complete. **Failure to follow these instructions may cause the bolts to misalign during assembly.**

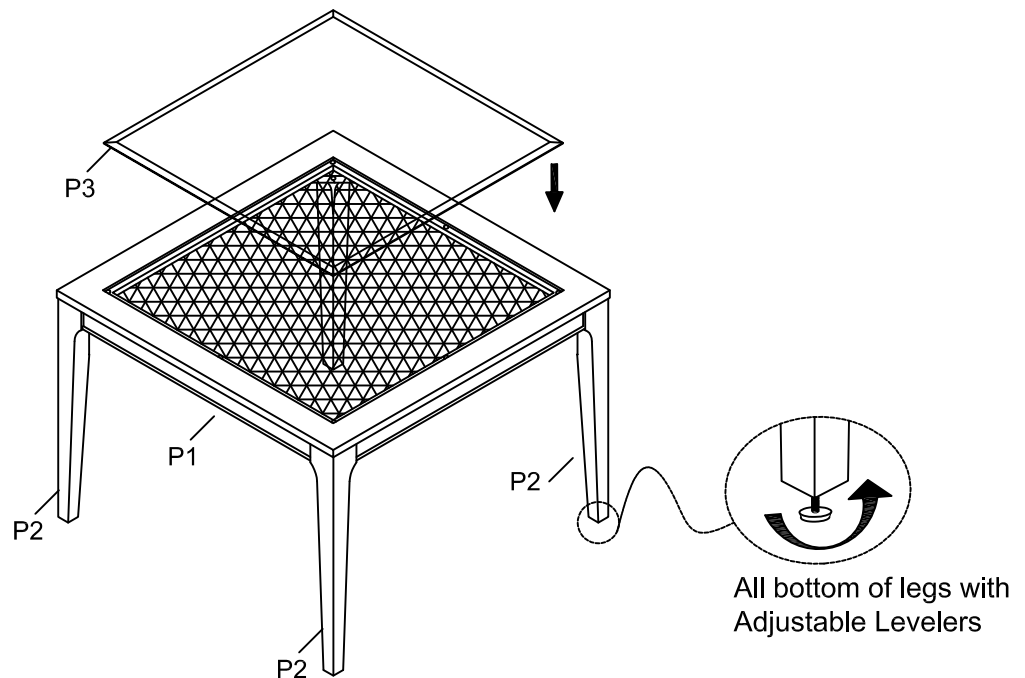

ADDITIONAL NOTE ABOUT SAFETY:
BOLTS MAY LOOSEN DURING NORMAL EVERYDAY USE.
THEY SHOULD BE INSPECTED AT LEAST EVERY 3 MONTHS AND RE-TIGHTENED AS NEEDED TO PREVENT DAMAGE OR INJURY,
AND ENSURE STABILITY.

Thank you for your purchase