

ASSEMBLY INSTRUCTIONS

Description: Crackle Counter Stool







Important safety instructions:

- Please read carefully all instructions before assembly.
- For your safety and ease, assembly by two or more adults is recommended.
- Keep instructions for future use.

Pre-assembly:





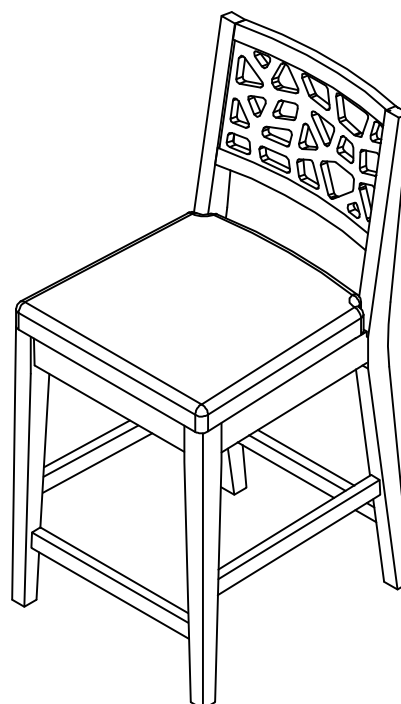

- Do not discard any content until assembly is complete to avoid accidentally discarding small parts or hardware.
- Take out all parts and hardware from box.

Parts List

Item	Description	QTY
P1	Chair Back 	1
P2	Seat Cushion 	1
P3	Left Front Leg  P3	1
P4	Right Front Leg  P4	1
P5	Left Stretcher  P5	1
P6	Right stretcher  P6	1
P7	Front stretcher 	1



Hardware List

Item	Description	QTY
H1	Long Bolts Ø5/16"x3-1/2" 	4
H2	Medium Bolts Ø5/16*2-1/2" 	4
H3	Short Bolt Ø5/16*1-3/4" 	1
H4	Lock Washers 5/16" 	9
H5	Flat Washers 5/16"(22mm) 	9
H6	Allen Wrench 5/16" 	1
H7	Screws 8#*1-5/8" 	6

DISCLAIMER:

WHEN PROPERLY ASSEMBLED, THIS ITEM IS SAFE FOR INTENDED USE. SELLER IS NOT LIABLE FOR ANY DAMAGES RESULTING FROM ITEM BEING IMPROPERLY ASSEMBLED AFTER PURCHASE.

Assembly Procedures:

Step 1. Assemble the stool on a flat, soft surface such as a carpet or cloth to prevent scratching the finish. Attach the seat cushion (B) to chair back (A) using bolts (c), locker washers (d) and flat washers (e). Loosely tighten by Allen wrench (f).

- (H3)x1 **Short Bolt** Ø5/16*1-3/4" 
- (H4)x1 **Lock Washers** 5/16" 
- (H5)x1 **Flat Washers** 5/16" 
- (H6)x1 **Allen Wrench** 5/16" 

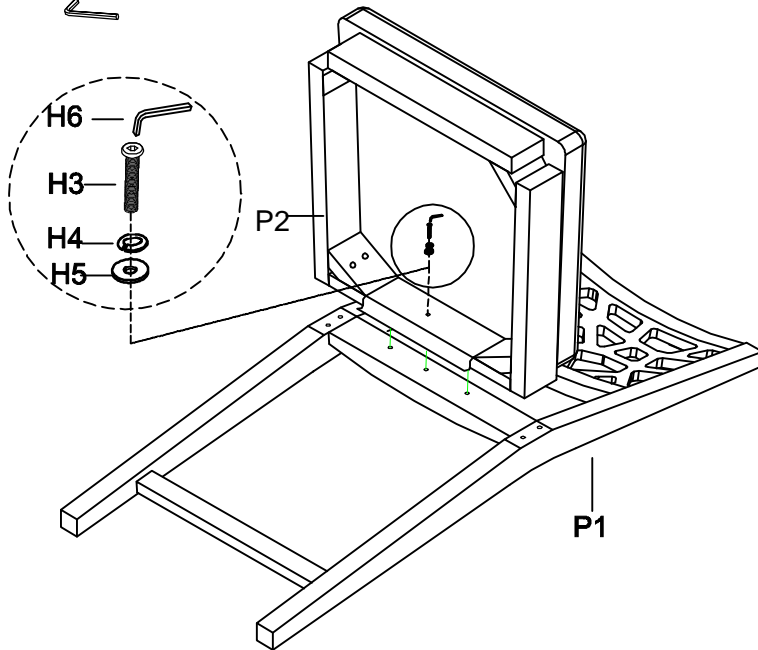

Step 2. Attach the seat cushion (P2) to chair back (P1) as shown below. Loosely tighten by Allen wrench (H6).

- (H1)x4 **Long Bolts** Ø5/16"x3-1/2" 
- (H4)x4 **Lock Washers** 5/16" 
- (H5)x4 **Flat Washers** 5/16" 
- (H6)x1 **Allen Wrench** 5/16" 

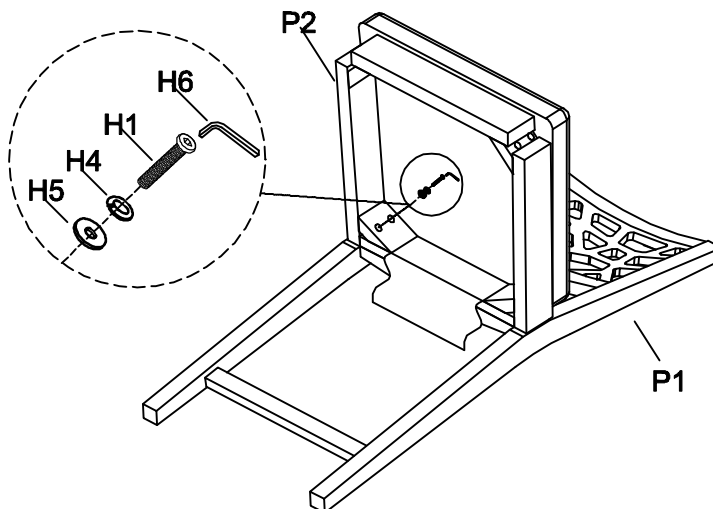

Step 3. 1) Insert the left front leg (P3) to the bottom of seat cushion (P2) according to the label "P3" on the corner block of seat cushion and the front legs top, then insert the left stretcher (P5) to the front leg (P3) and chair back legs according to the label "P5" at the holes in the legs and the front end of stretcher (P5). Loosely attach the front leg (P3) to the seat cushion (P2) as shown below. Do not tighten the bolts at this time.

- (H2)x2 **Medium Bolts Ø5/16*2-1/2"**
- (H4)x2 **Lock Washers 5/16"**
- (H5)x2 **Flat Washers 5/16"**
- (H6)x1 **Allen Wrench 5/16"**

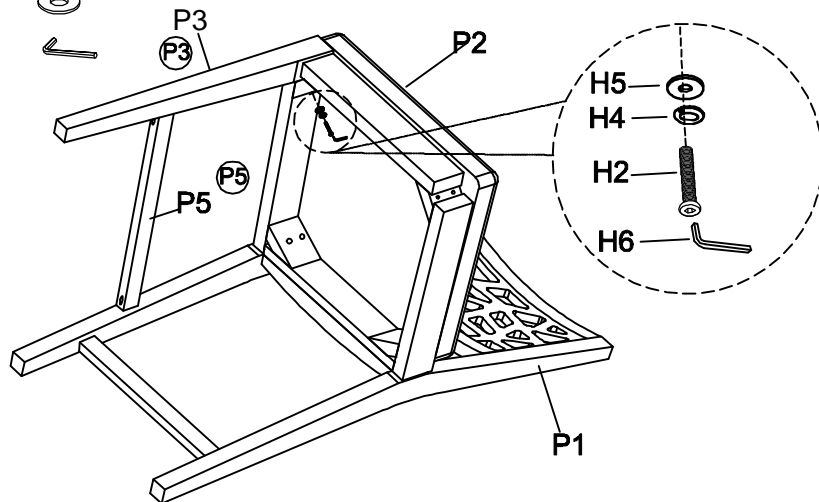

Step 4.

- 1) Insert the right front leg (P4) to the bottom of seat cushion (P2) according to the label "P4" on the corner block of seat cushion and the front legs top, then insert the right stretcher (P6) to the front leg (P4) and chair back legs according to the label "P6" at the holes in the legs and the front end of stretcher (P6). Loosely attach the front leg (P4) to the seat cushion (P2) as shown below. Do not tighten the bolts at this time.
- 2) Insert the front stretcher (P7) between the front legs (P3 & P4)
- 3) Securely tighten all bolts, but do not over tighten the bolts.
- 4) Tighten all screws (H7) through the stretchers (P5, P6, P7) to the front legs and chair back legs.
- 5) Assembly is complete.

- (H2)x2 **Medium Bolts Ø5/16*2-1/2"**
- (H4)x2 **Lock Washers 5/16"**
- (H5)x2 **Flat Washers 5/16"**
- (H6)x1 **Allen Wrench 5/16"**
- (H7)x6 **Screws 8#*1-5/8"**

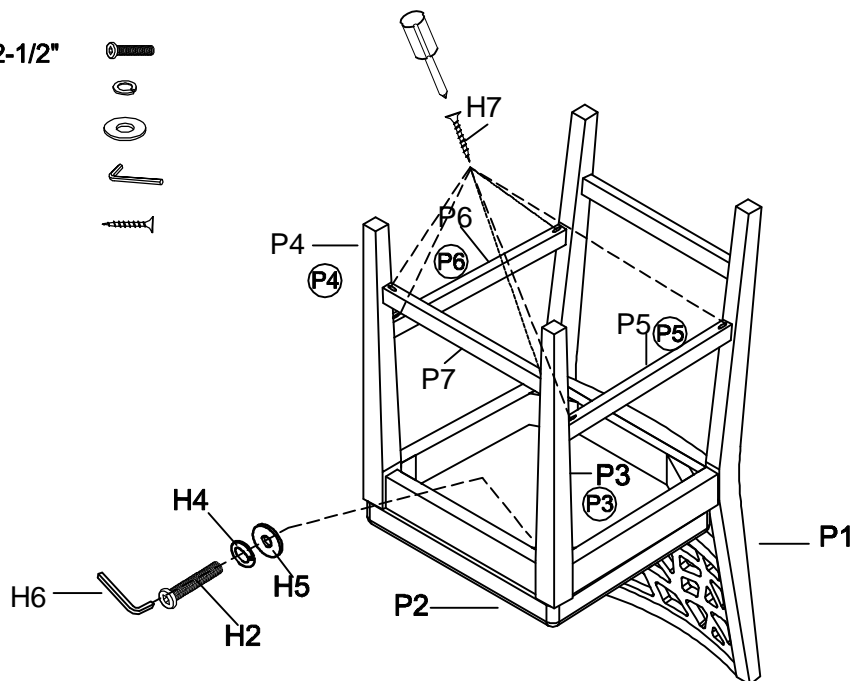

ADDITIONAL NOTE ABOUT SAFETY: BOLTS MAY LOOSEN DURING NORMAL EVERYDAY USE. THEY SHOULD BE PERIODICALLY INSPECTED AND RE-TIGHTENED TO PREVENT DAMAGE OR INJURY. ALWAYS CHECK TO ENSURE THAT ALL HARDWARE IS KEPT TIGHTENED.

Thank you for your purchase