

ASSEMBLY INSTRUCTIONS

Description: Melbourne Lounge Chair









Important safety instructions:

- Please read carefully all instructions before assembly.
- For your safety and ease, assembly by two or more adults is recommended.
- Keep instructions for future use.

Pre-assembly:

- Do not discard any content until assembly is complete to avoid accidentally discarding small parts or hardware.
- Take out all parts and hardware from box.

Parts List

Item	Description		QTY
P1	Seat Cushion		1
P2	Back Frame		1
P3	Left Leg	 	1
P4	Right Leg	 	1
P5	Stretcher 1 with two holes		2
P6	Stretcher 2		2
P7	Back Cushion		1

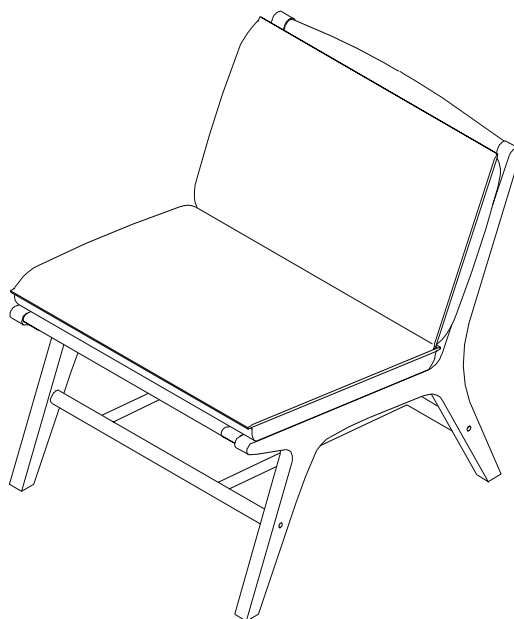

Hardware List





Item	Description		QTY
H1	Bolts Ø1/4*3"		4
H2	Bolts Ø1/4*2"		8
H3	Lock Washers Ø1/4"		12
H4	Big Flat Washers Ø1/4" *19mm		4
H5	Small Flat Washers Ø1/4" *12mm		8
H6	Allen Wrench 1/4"		1
H7	Wooden Plugs		8

DISCLAIMER:

WHEN PROPERLY ASSEMBLED, THIS ITEM IS SAFE FOR INTENDED USE. SELLER IS NOT LIABLE FOR ANY DAMAGES RESULTING FROM ITEM BEING IMPROPERLY ASSEMBLED AFTER PURCHASE.

Assembly Procedures:

Step 1. Assemble the chair on a flat, soft surface such as a carpet or cloth to prevent scratching the finish. Attach seat cushion (P1) and back frame (P2) to the left leg (P3) according to the label "P3" on the left leg. Securely tighten all bolts with Allen wrench (H6).



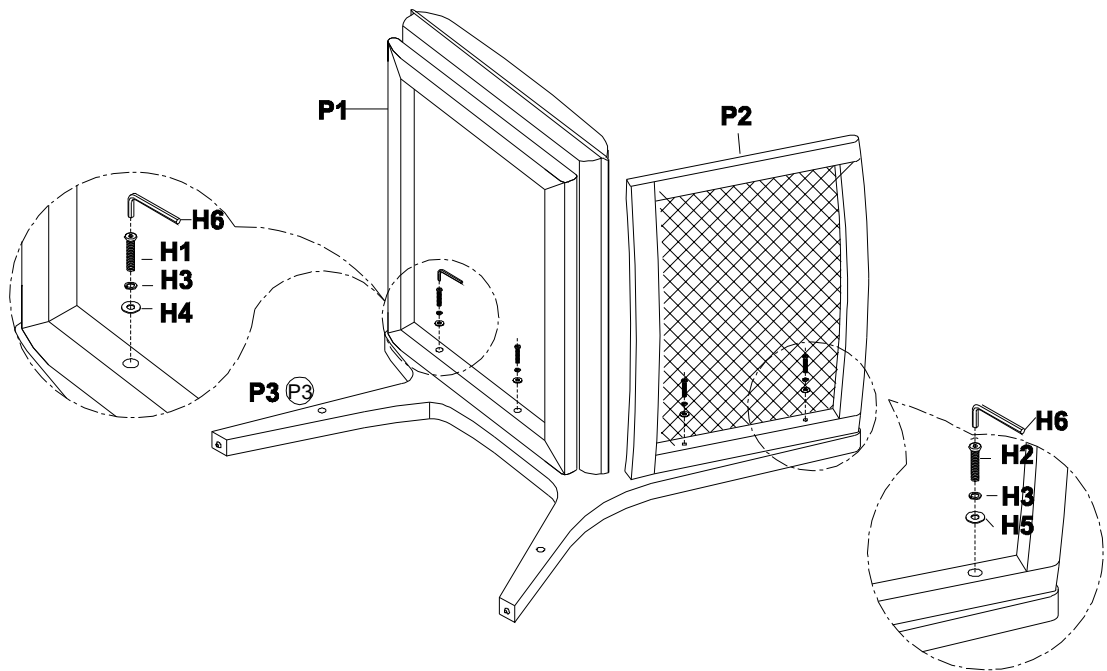

- (H1)x2 Bolts $\varnothing 1/4 \times 3$ " 
- (H2)x2 Bolts $\varnothing 1/4 \times 2$ " 
- (H3)x4 Lock Washers 
- (H4)x2 Big Flat Washers 
- (H5)x2 Small Flat Washers 

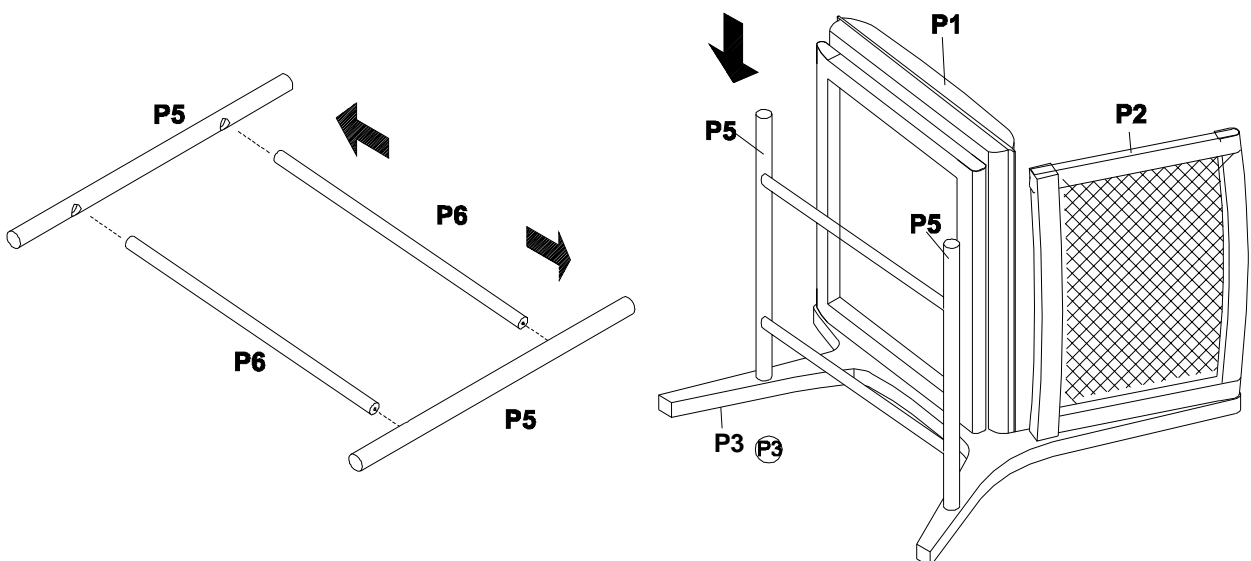

Step 2. Insert stretchers 2 (P6) to the holes on the stretchers 1 with two holes (P5). then insert the assembled stretcher 1 (P5) to the holes of left leg (P3).



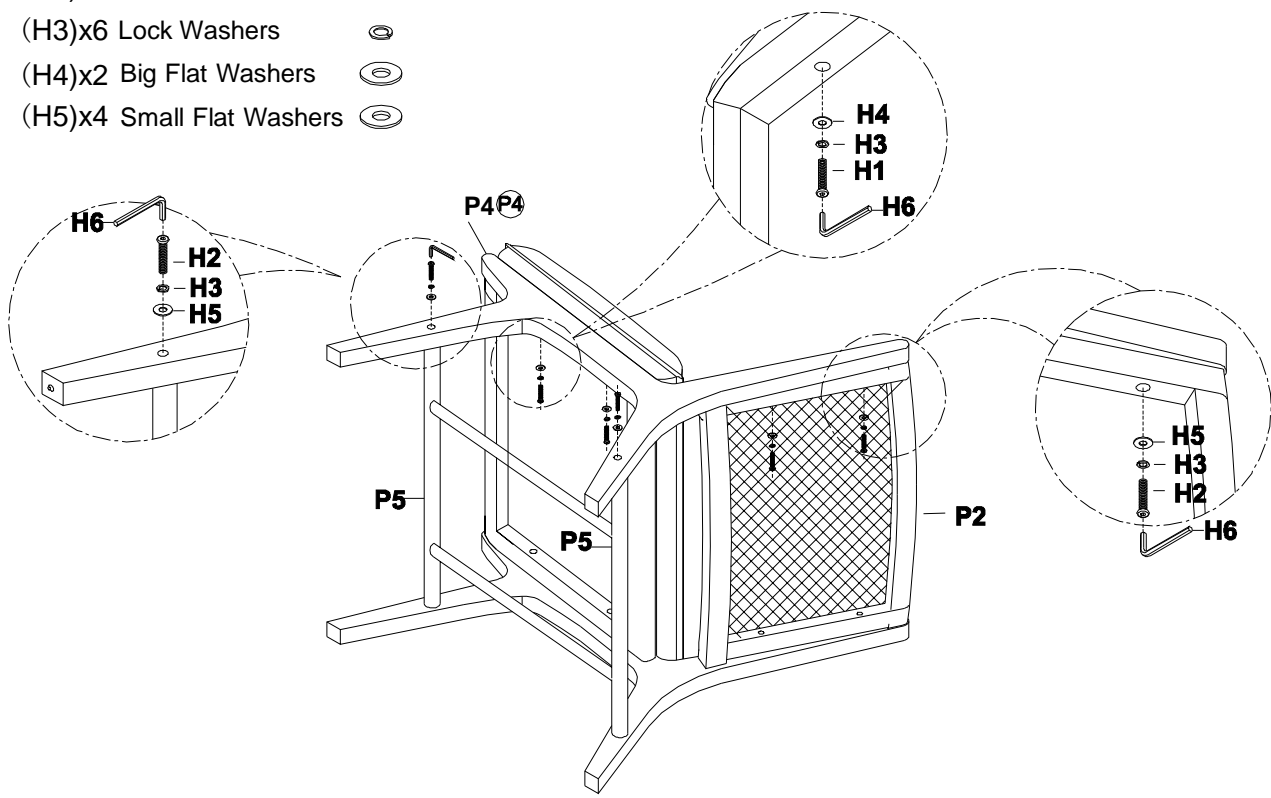

Step 3. Loosely attach right leg (P4) to the seat cushion (P1), back frame (P2) and stretchers 2 (P6) according to the label "P4" on the right leg as show below. Securely tighten all bolts with Allen wrench (H6).

- (H1)x2 Bolts Ø1/4*3" 
- (H2)x4 Bolts Ø1/4*2" 
- (H3)x6 Lock Washers 
- (H4)x2 Big Flat Washers 
- (H5)x4 Small Flat Washers 



Step 4. Lay the other right leg (P4) on a flat, soft surface such as a carpet or cloth. Then attach the stretcher 1 (P5) and the stretcher (P5). Repeat assembled left leg (P3) to stretchers 1 (P5) according to the label "P3" on the left leg. Securely tighten all bolts with Allen wrench (H6).

- (H2)x2 Bolts Ø1/4*2" 
- (H3)x2 Lock Washers 
- (H5)x2 Small Flat Washers 

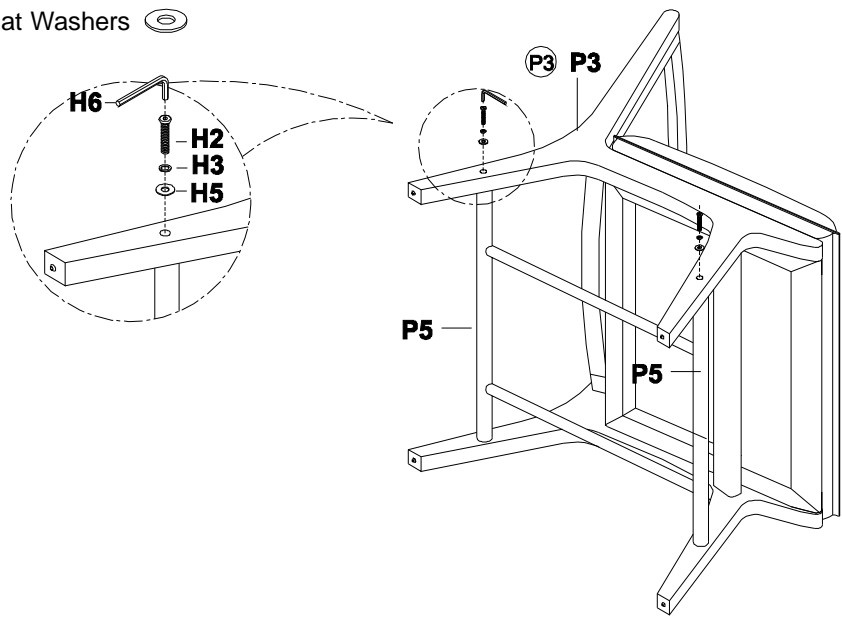

Step 5.

- 1) Turn the assembled chair to an upright position. Securely tighten all the bolts with Allen wrench (f).
- 2) Attach wooden plugs (H7) to each bolt hole, tighten with rubber hammer to knock the wooden plug till its tighten. Note: use a soft cloth between the wooden plug and hammer to prevent damage to wooden plug finish.
- 3) Assembly is complete. Put the back cushion (P7) on the assembled lounge.

(H7)x8 Wooden Plugs 

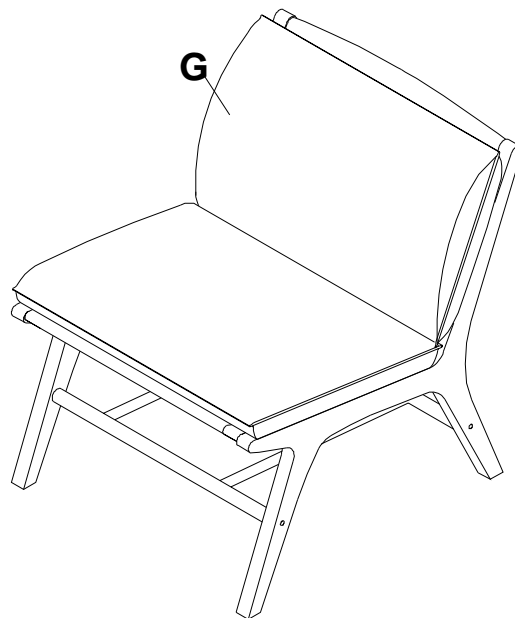
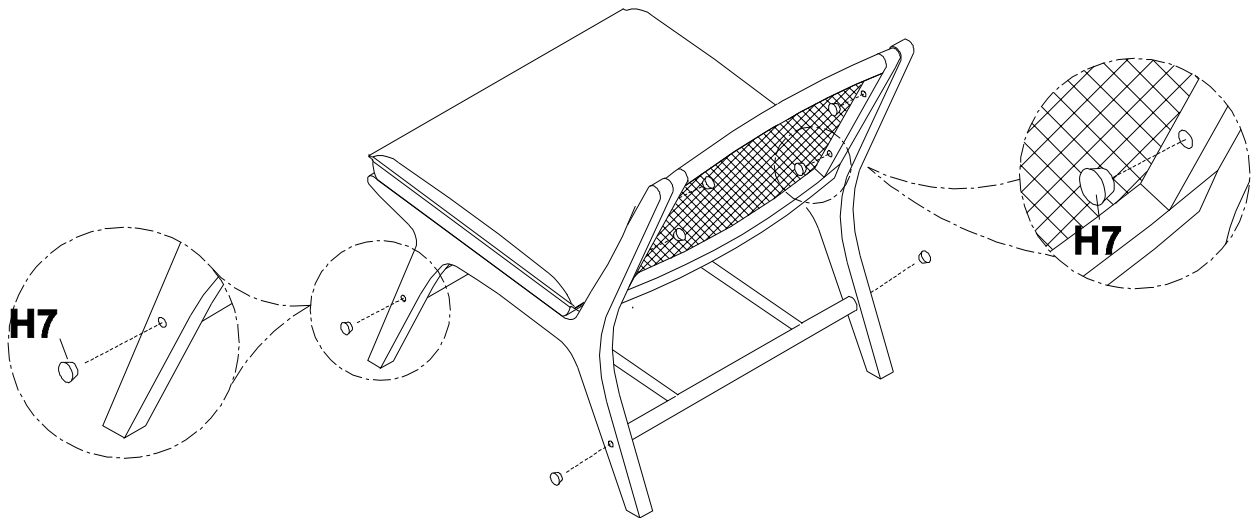

ADDITIONAL NOTE ABOUT SAFETY: BOLTS MAY LOOSEN DURING NORMAL EVERYDAY USE. THEY SHOULD BE PERIODICALLY INSPECTED AND RE-TIGHTENED TO PREVENT DAMAGE OR INJURY. ALWAYS CHECK TO ENSURE THAT ALL HARDWARE IS KEPT TIGHTENED.

Thank you for your purchase