

**Important safety instructions:**

- Please read carefully all instructions before assembly.
- For your safety and ease, assembly by two or more adults is recommended.
- Keep instructions for future use.

**Pre-assembly:**

- Do not discard any content until assembly is complete to avoid accidentally discarding small parts or hardware.
- Take out all parts and hardware from box.

Parts List

Item	Description	QTY
P1	Right leg	1
P2	Left legs	1
P3	Top	1
P4	Strecher	1

Hardware List

Item	Description	QTY
H1	BOLTS $\varnothing\frac{1}{4}$ " x $\frac{1}{2}$ "L	02
H2	FLAT WASHERS $\varnothing\frac{1}{4}$ "	02
H3	LOCK WASHERS $\varnothing\frac{1}{4}$ "	02
H4	BOLTS $\varnothing\frac{5}{16}$ " x 2"L	10
H5	FLAT WASHERS $\varnothing\frac{5}{16}$ "	10
H6	LOCK WASHERS $\varnothing\frac{5}{16}$ "	10
H7	ALLEN KEY	1

**DISCLAIMER: WHEN PROPERLY ASSEMBLED, THIS ITEM IS SAFE FOR INTENDED USE. SELLER IS NOT LIABLE FOR ANY DAMAGES RESULTING FROM ITEM BEING IMPROPERLY ASSEMBLED AFTER PURCHASE.**

**Assembly Procedures:**

Step 1: Assemble the DESK on a flat, soft surface such as a carpet or cloth to prevent scratching the finish. Attach right leg (P2) to table top (P3) using Lock washer (H6), Flat washer (H5) and Bolt (H4) as shown below.

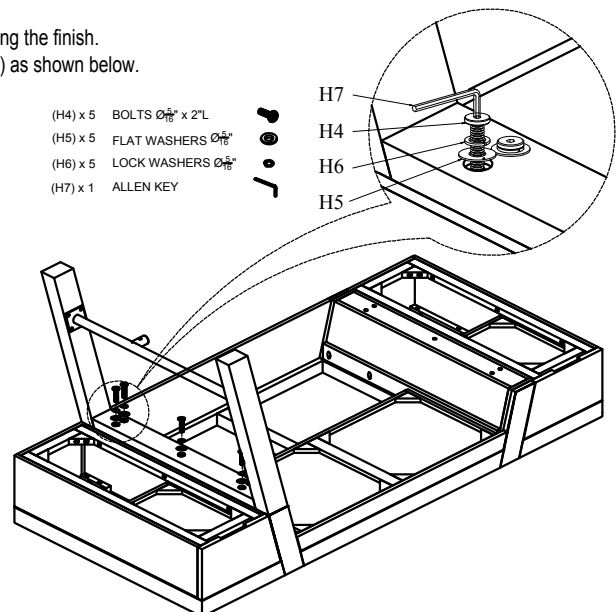
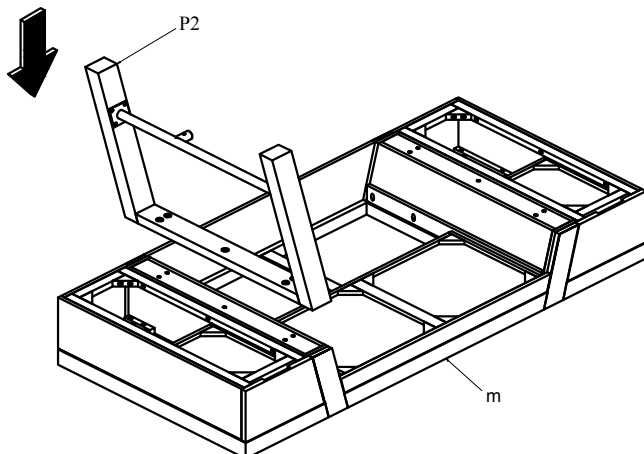

\* DON'T TIGHTEN BOLTS UNTIL STEP 3

Step 2: Attach metal stretcher (P4) to right leg (P2) using Lock washer (H3), Flat washer (H2) and Bolt (H1) as shown below.

- (H1) x 1 BOLTS  $\varnothing_{\frac{11}{16}} \times 2''L$
- (H2) x 1 FLAT WASHERS  $\varnothing_{\frac{11}{16}}$
- (H3) x 1 LOCK WASHERS  $\varnothing_{\frac{11}{16}}$
- (H7) x 1 ALLEN KEY

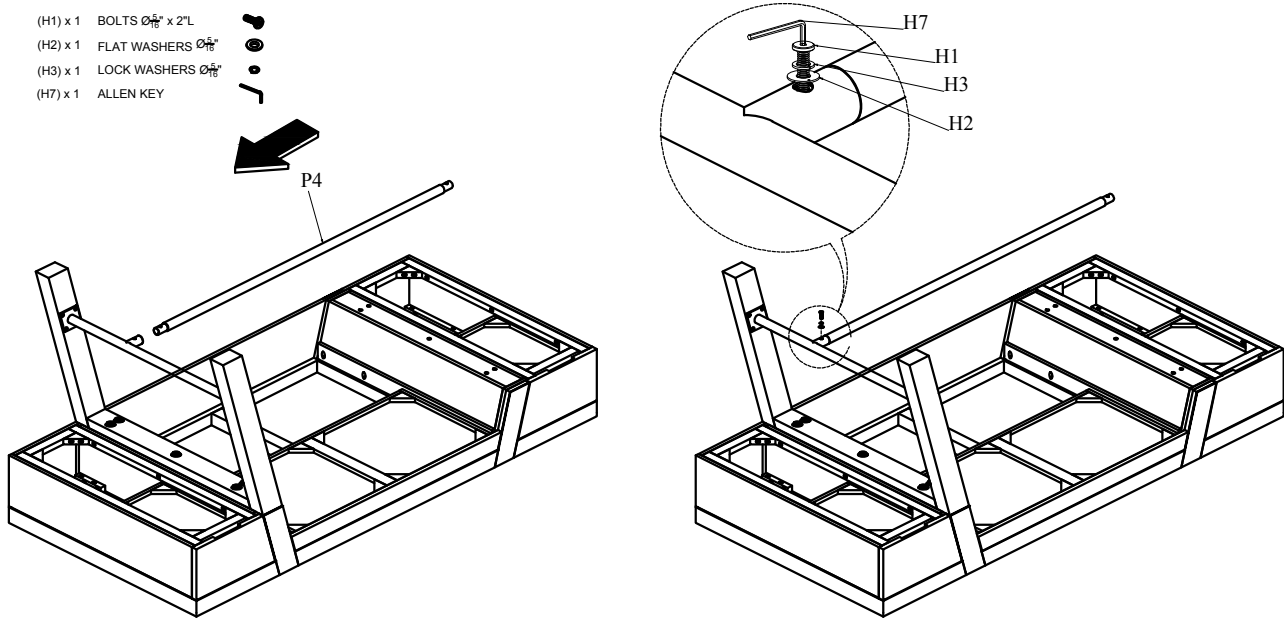

Step 3: Attach left leg (P1) to table top (P3) and metal stretcher (P4) using Allen key (H7), Lock washer (H3), Flat washer (H2) and Bolt (H1) and Lock washer (H6), Flat washer (H5) and Bolt (H4) as shown below.

- (H1) x 1 BOLTS  $\varnothing_{\frac{11}{16}} \times 2''L$
- (H2) x 1 FLAT WASHERS  $\varnothing_{\frac{11}{16}}$
- (H3) x 1 LOCK WASHERS  $\varnothing_{\frac{11}{16}}$
- (H4) x 5 BOLTS  $\varnothing_{\frac{11}{16}} \times 2''L$
- (H5) x 5 FLAT WASHERS  $\varnothing_{\frac{11}{16}}$
- (H6) x 5 LOCK WASHERS  $\varnothing_{\frac{11}{16}}$
- (H7) x 1 ALLEN KEY

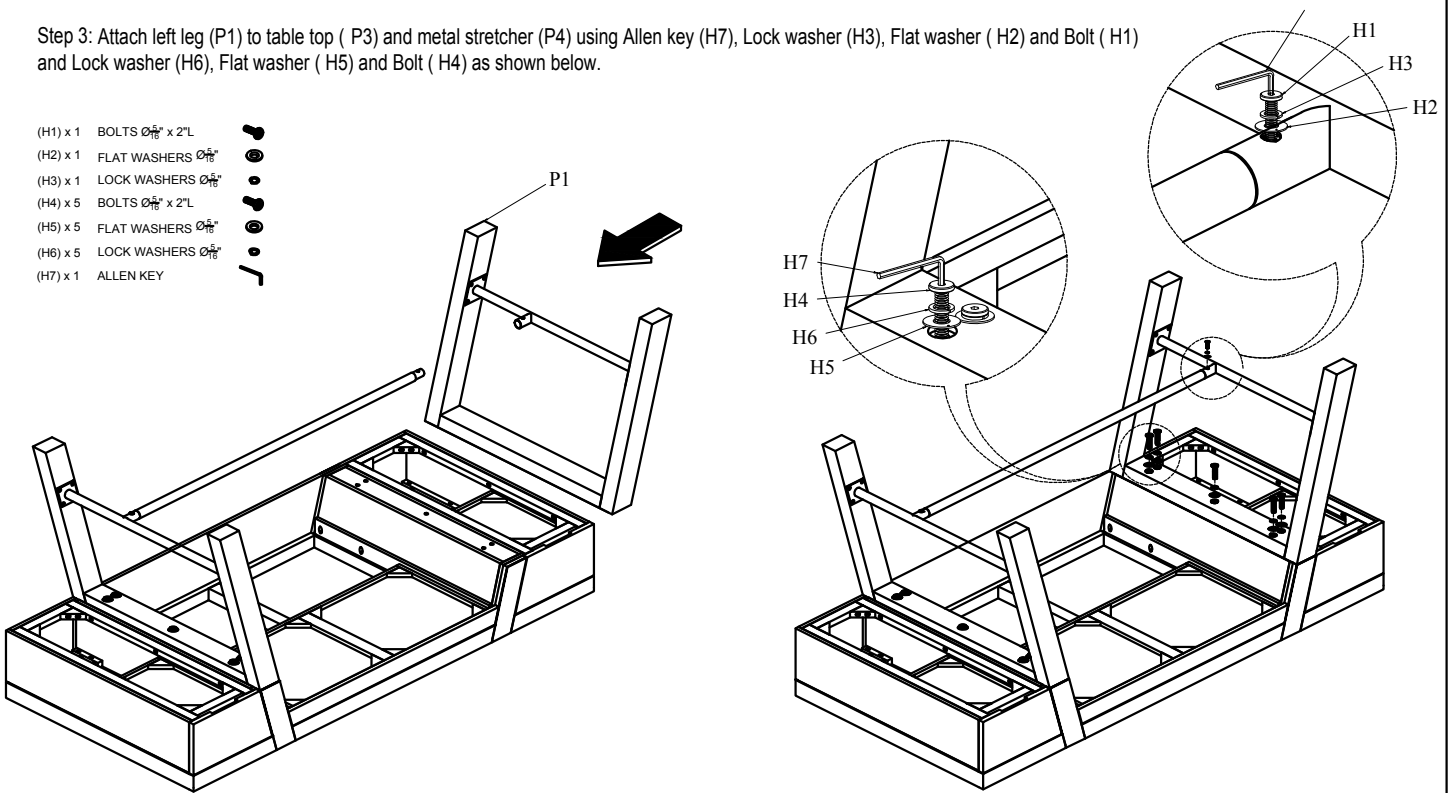

Step 4: Turn the assemble desk to an upright position. Assembly is complete.

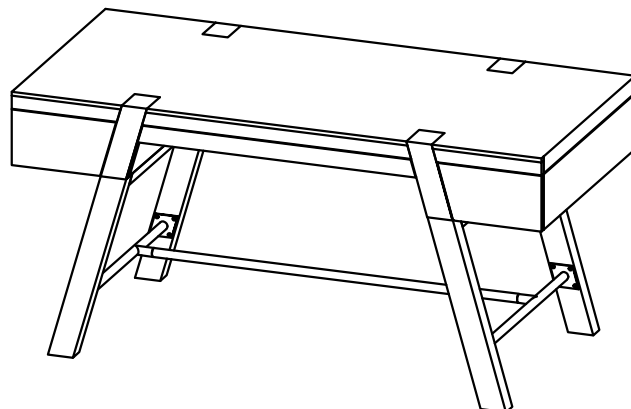

**ADDITIONAL NOTE ABOUT SAFETY: BOLTS MAY LOOSEN DURING NORMAL EVERYDAY USE. THEY SHOULD BE PERIODICALLY INSPECTED AND RE-TIGHTENED TO PREVENT DAMAGE OR INJURY. ALWAYS CHECK TO ENSURE THAT ALL HARDWARE IS KEPT TIGHTENED.**

Thank you for your purchase