

ASSEMBLY INSTRUCTIONS

Description: Carson Counter stool

Important safety instructions:

- Please read carefully all instructions before assembly.
- For your safety and ease, assembly by two or more adults is recommended.
- Keep instructions for future use.

Pre-assembly:

- Do not discard any content until assembly is complete to avoid accidentally discarding small parts or hardware.
- Take out all parts and hardware from box.

Parts List

Item	Description	QTY
P1	Chair Top	1
P2	Chair Base	1

Hardware List

Item	Description	QTY
H1	Short Bolts $\varnothing 1/4'' \times 1-1/4'' L$	8
H2	Lock Washers 1/4"	8
H3	Flat Washers 1/4"	8
H4	Allen Wrench 1/4"	1
H5	Swivel	1

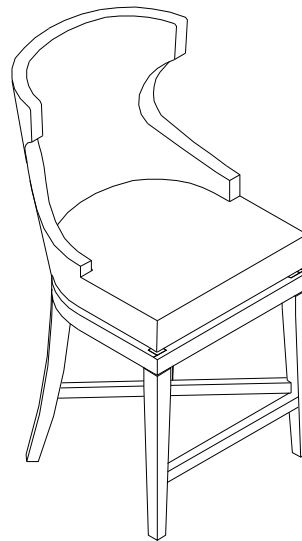

DISCLAIMER:

WHEN PROPERLY ASSEMBLED, THIS ITEM IS SAFE FOR INTENDED USE. SELLER IS NOT LIABLE FOR ANY DAMAGES RESULTING FROM ITEM BEING IMPROPERLY ASSEMBLED AFTER PURCHASE.

Assembly Procedures:

Step 1. Assemble the stool on a flat, soft surface such as a carpet or cloth to prevent scratching the finish. Attach the swivel (H5) to the top of chair base (P2) as shown below.

- (H1)x4 Bolts $\varnothing 1/4'' \times 1-1/4'' L$ 
- (H2)x4 Lock Washers 1/4" 
- (H3)x4 Flat Washers 1/4" 
- (H4)x1 Allen Wrench 1/4" 
- (H5)x1 Swivel 

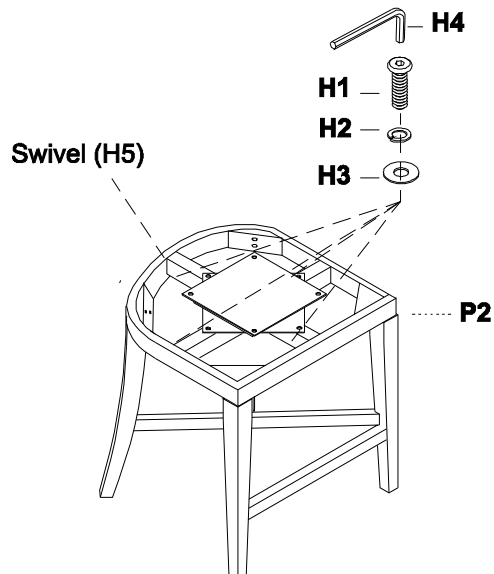
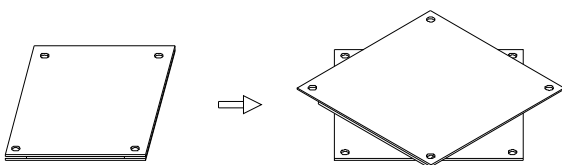

Step 2. Attach the chair base (P2) to the chair top (P1) as shown below.

(H1)x4 Bolts $\varnothing 1/4" \times 1-1/4" L$



(H2)x4 Lock Washers 1/4"



(H3)x4 Flat Washers 1/4"



(H4)x1 Allen Wrench 1/4"

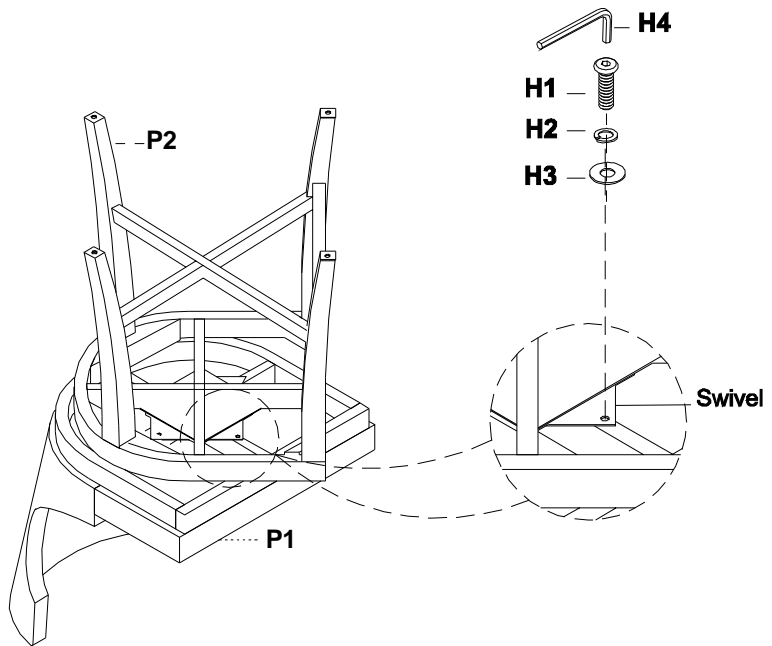

Step 2. Turn the assembled stool to an upright position. Make sure the stool is level and securely tighten all bolts with Allen wrench (H4). Assembly is complete. **Failure to follow these instructions may cause the bolts to misalign during assembly.**

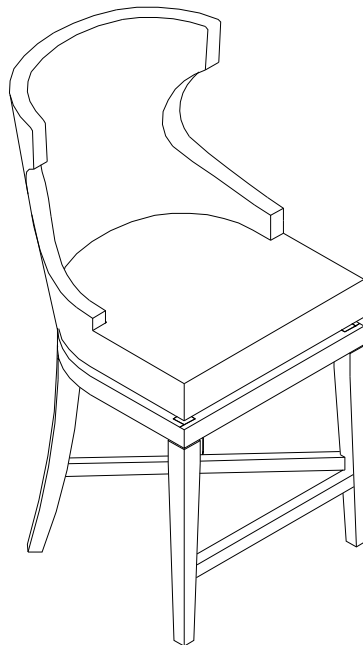

ADDITIONAL NOTE ABOUT SAFETY: BOLTS MAY LOOSEN DURING NORMAL EVERYDAY USE. THEY SHOULD BE PERIODICALLY INSPECTED AND RE-TIGHTENED TO PREVENT DAMAGE OR INJURY. ALWAYS CHECK TO ENSURE THAT ALL HARDWARE IS KEPT TIGHTENED.

Thank you for your purchase