

ASSEMBLY INSTRUCTIONS

Description: Counter & Bar Stool







Important safety instructions:

- Please read carefully all instructions before assembly.
- For your safety and ease, assembly by two or more adults is recommended.
- Keep instructions for future use.

Pre-assembly:





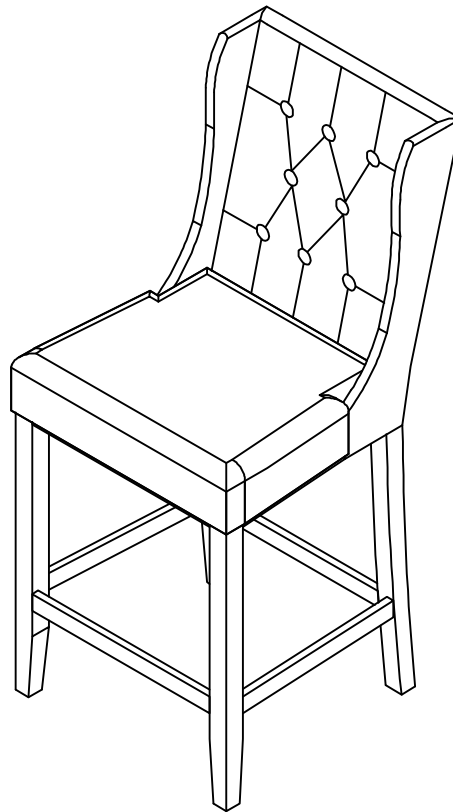

- Do not discard any content until assembly is complete to avoid accidentally discarding small parts or hardware.
- Take out all parts and hardware from box.

Parts List

Item	Description	QTY
P1	Stool Back 	1
P2	Seat Cushion 	1
P3	Left Stretcher  Ⓛ	1
P4	Right Stretcher  Ⓡ	1
P5	Front Stretcher 	1
P6	Front Legs 	2



Hardware List

Item	Description	QTY
H1	Long Bolts Ø5/16**2-1/4" 	6
H2	Short Bolts Ø5/16**2" 	2
H3	Lock Washers 5/16" 	8
H4	Flat Washers 5/16" 	8
H5	Allen Wrench 5/16" 	1
H6	Screws #8*1-3/4" 	6

DISCLAIMER:

WHEN PROPERLY ASSEMBLED, THIS ITEM IS SAFE FOR INTENDED USE. SELLER IS NOT LIABLE FOR ANY DAMAGES RESULTING FROM ITEM BEING IMPROPERLY ASSEMBLED AFTER PURCHASE.

Assembly Procedures:

Step 1, Assemble the stool on a flat, soft surface such as a carpet or cloth to prevent scratching the finish.

1) The seat cushion (P2) should be placed from bottom of chair back's wing and then pushed to the proper location (Between the two wings as shown below**).**

2) Make sure the seat cushion (P2) to the stool back (P1) aligning the holes. Loosely tighten the bolts with Allen wrench (H5).

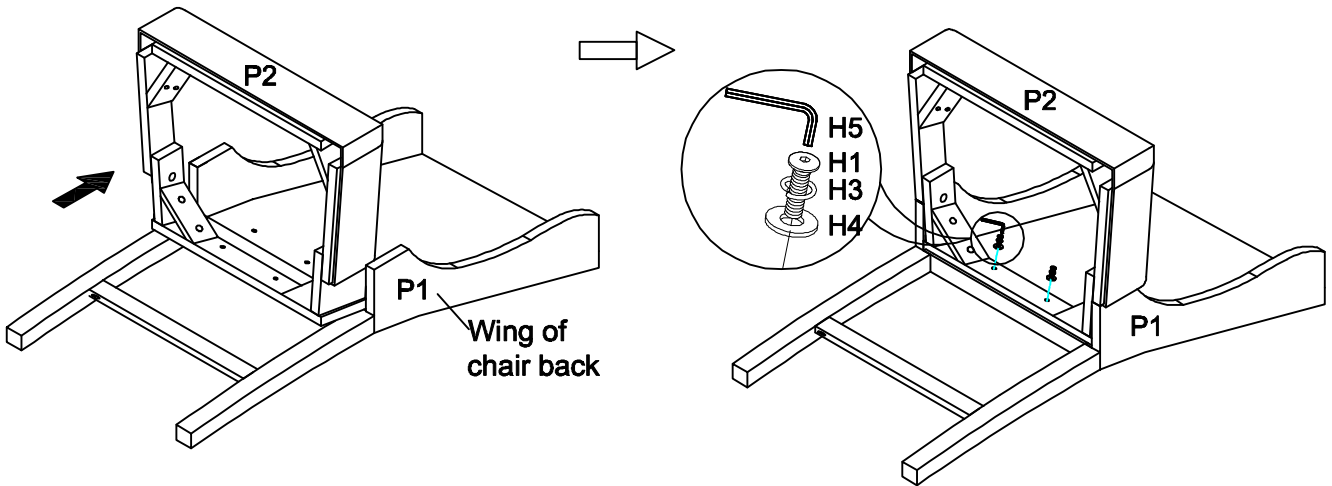

Step 2. Attach the seat cushion (P2) to the side of stool back (P1) as shown below. Loosely tighten the bolts with Allen wrench (H5).

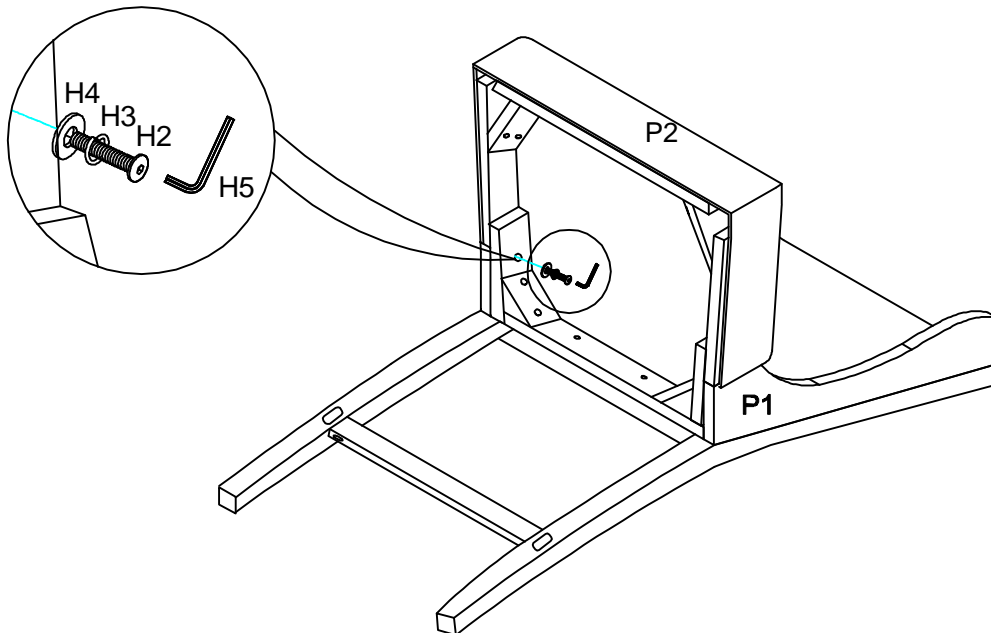

Step 3. Insert the right stretcher (P4) to the leg of stool back (P1) according to the label "R" at the hole in the leg of stool back and the front end of right stretcher (P4). Loosely attach the front leg (P6) to the bottom of seat cushion (P2) and the stretcher (P4) as shown below. Do not tighten the bolts at this time.

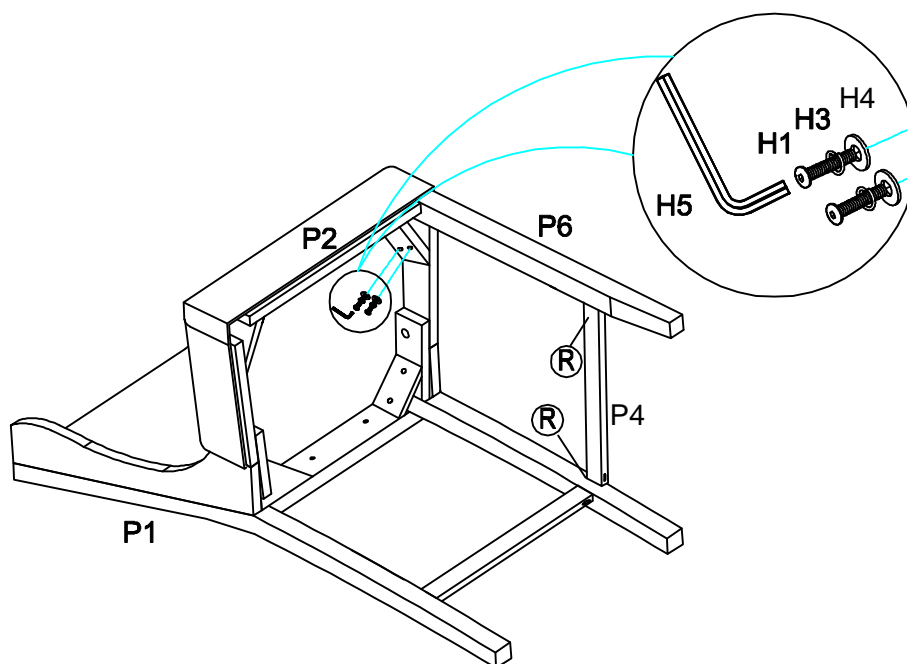

Step 4.

- 1) Insert the left stretcher (P3) to the leg of stool back (P1) according to the label "L" at the holes in the legs of stool back and the front end of left stretcher (P3). Loosely attach the front leg (P6) to the seat cushion (P2) as shown below. Do not tighten the bolts at this time.
- 2) Insert the front stretcher (P5) between the front legs (P6).
- 3) Securely tighten all bolts, but do not over tighten the bolts.
- 4) Tighten all screws (H6) through the stretchers (P3, P4, P5) to the front legs (P6) and stool back legs with screw driver (not provided).

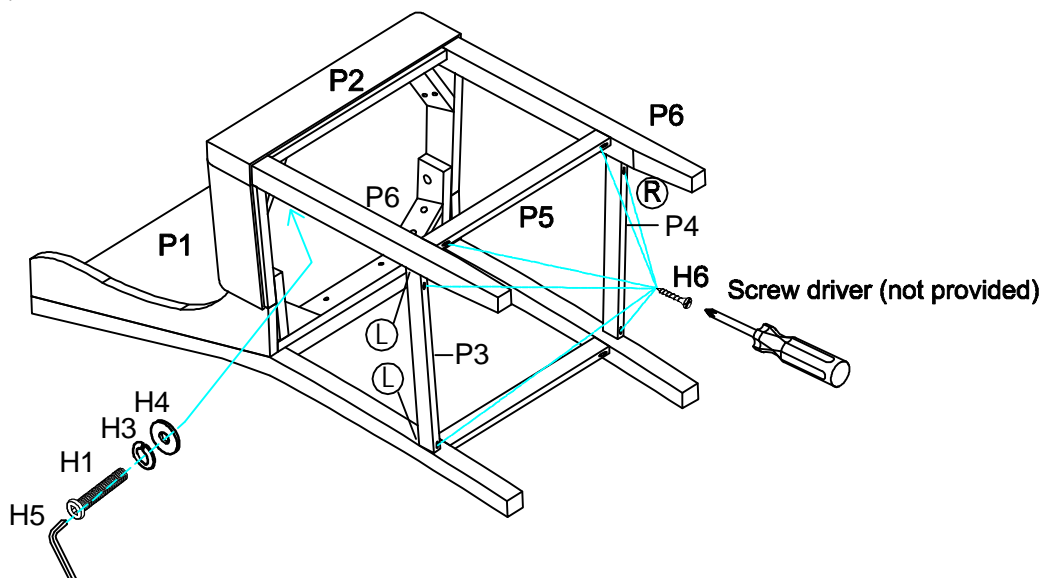

ADDITIONAL NOTE ABOUT SAFETY: BOLTS MAY LOOSEN DURING NORMAL EVERYDAY USE. THEY SHOULD BE PERIODICALLY INSPECTED AND RE-TIGHTENED TO PREVENT DAMAGE OR INJURY. ALWAYS CHECK TO ENSURE THAT ALL HARDWARE IS KEPT TIGHTENED.

Thank you for your purchase