

# MADISON PARK® ASSEMBLY INSTRUCTIONS

Description: Boulder Dining Table





**Important safety instructions:**

- Please read carefully all instructions before assembly.
- For your safety and ease, assembly by two or more adults is recommended.
- Keep instructions for future use.

**Pre-assembly:**

- Do not discard any content until assembly is complete to avoid accidentally discarding small parts or hardware.
- Take out all parts and hardware from box.

**Parts List**

Item	Description	QTY
P1	Table Top 	2
P2	Metal Side Frame 	2
P3	Support Rail 	3
P4	Metal Stretcher 	1

**Hardware List**

Item	Description	QTY
H1	Small Short Bolt Ø1/4"x1/2" 	4
H2	Small Long Bolt Ø1/4"x1-3/4" 	18
H3	Big Short Bolt Ø5/16"x3/4" 	6
H4	Big Long Bolt Ø5/16"x1-1/4" 	4
H5	Small Lock Washer 1/4" 	18
H6	Small Flat Washer 1/4" 	18
H7	Big Lock Washer 5/16" 	10
H8	Big Flat Washer 5/16" 	10
H9	Small Allen Wrench 1/4" 	1
H10	Big Allen Wrench 5/16" 	1

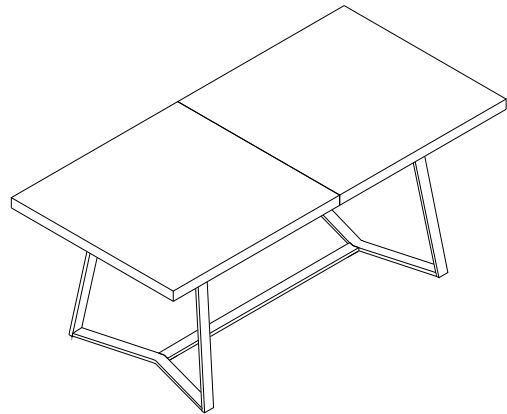

**DISCLAIMER:**

WHEN PROPERLY ASSEMBLED, THIS ITEM IS SAFE FOR INTENDED USE. SELLER IS NOT LIABLE FOR ANY DAMAGES RESULTING FROM ITEM BEING IMPROPERLY ASSEMBLED AFTER PURCHASE.

**Assembly Procedures:**

**Step 1. Assemble the table on a flat, soft surface such as a carpet or cloth to prevent scratching the finish. Attach two table tops (P1) together by locking the locks as shown below image 1.**

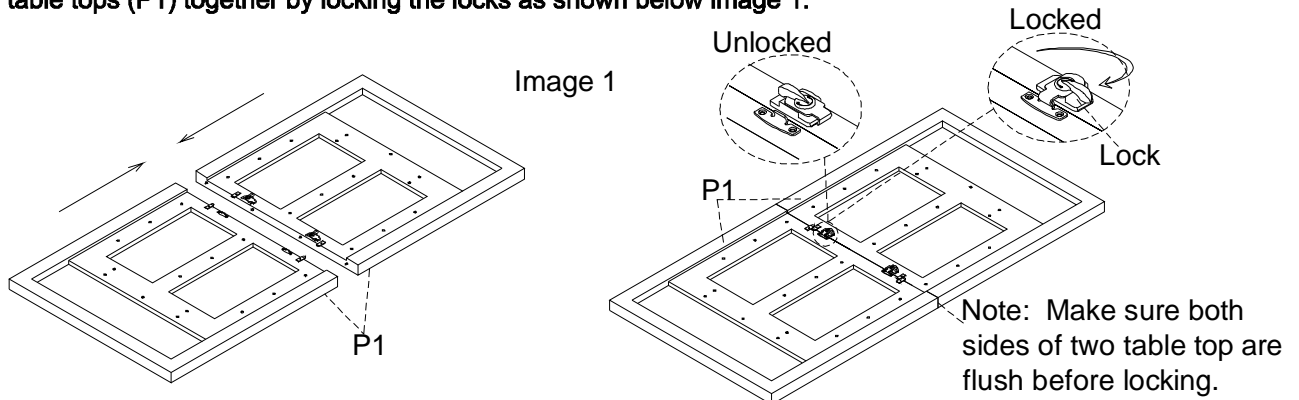

Step 2. Attach the support rails (P3) to the assembled table tops (P1) as shown below image 2. Securely tighten all bolts with Allen wrench (H8) .

- (H2)x18 Small Long Bolt  $\varnothing 1/4$ "x1-3/4"
- (H5)x18 Small Lock Washer 1/4"
- (H6)x18 Small Flat Washer 1/4"
- (H9)x1 Small Allen Wrench 1/4"

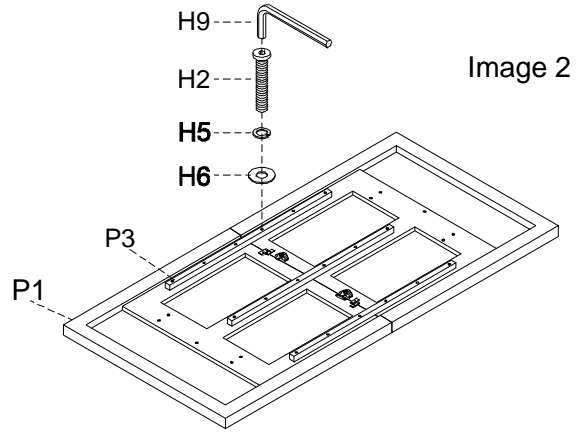

Step 3. Loosely attach the metal side frames (P2) to the assembled table tops (P1) as shown below image 3.

- (H3)x6 Big Short Bolt  $\varnothing 5/16$ "x3/4"
- (H4)x4 Big Long Bolt  $\varnothing 5/16$ "x1-1/4"
- (H7)x10 Big Lock Washer 5/16"
- (H8)x10 Big Flat Washer 5/16"
- (H10)x1 Big Allen Wrench 5/16"

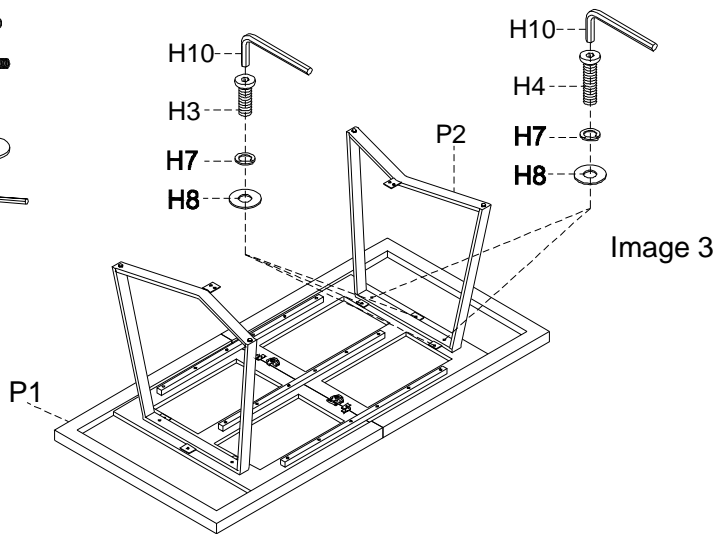

Step 4.

- a) Attach the metal stretcher (P4) to the side frames (P2) , securely tighten all bolts with Allen wrench (H9 & H10).
- b) To level Table: After completing all other steps, turn the assembled table to an upright position . If there is a gap between the base and the floor , please adjust the adjustable leveler up or down.
- c) Assembly is complete. **Failure to follow these instructions may cause the bolts to misalign during assembly.**

- (H1)x4 Small Short Bolt  $\varnothing 1/4$ "x1/2"
- (H9)x1 Small Allen Wrench 1/4"

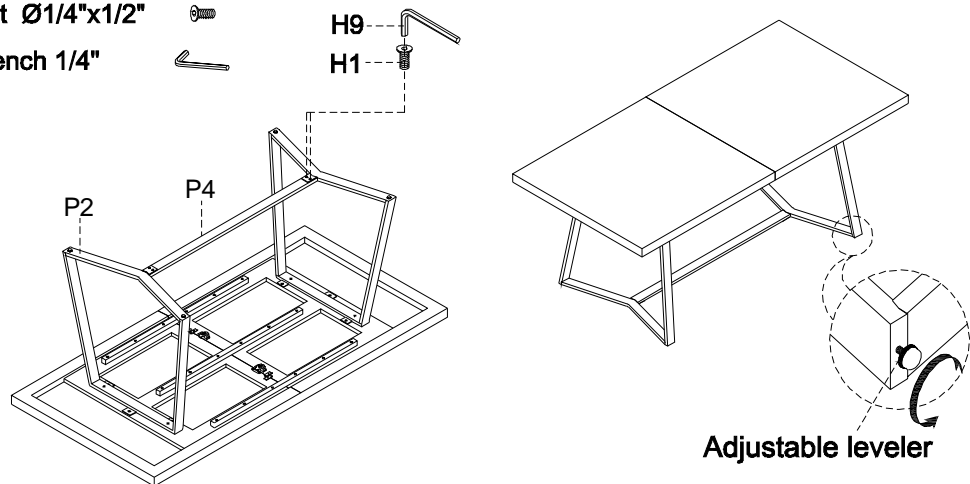

ADDITIONAL NOTE ABOUT SAFETY: BOLTS MAY LOOSEN DURING NORMAL EVERYDAY USE. THEY SHOULD BE PERIODICALLY INSPECTED AND RE-TIGHTENED TO PREVENT DAMAGE OR INJURY. ALWAYS CHECK TO ENSURE THAT ALL HARDWARE IS KEPT TIGHTENED.

Thank you for your purchase