

ASSEMBLY INSTRUCTIONS

Description: Malibu Lounge







Important safety instructions:

- Please read carefully all instructions before assembly.
- For your safety and ease, assembly by two or more adults is recommended.
- Keep instructions for future use.









Pre-assembly:

- Do not discard any content until assembly is complete to avoid accidentally discarding small parts or hardware.
- Take out all parts and hardware from box.

Parts List

Item	Description	QTY
P1	Right Arm  (R)	1
P2	Left Arm  (L)	1
P3	Seat Cushion 	1
P4	Back Cushion 	1
P5	Seat Frame 	1
P6	Back Frame 	1
P7	Stretcher 	1

Hardware List

Item	Description	QTY
H1	Long Bolts $\text{Ø}1/4\text{"x}3\text{"}$ 	2
H2	Short Bolts $\text{Ø}1/4\text{"x}2\text{"}$ 	10
H3	Lock Washers $1/4\text{"}$ 	12
H4	Big flat washers $1/4\text{"}$ (19mm) 	10
H5	Small flat washers $1/4\text{"}$ (12mm) 	2
H6	Allen Wrench $1/4\text{"}$ 	1
H7	Wooden Plugs 	2
H8	Open Wrench 	1

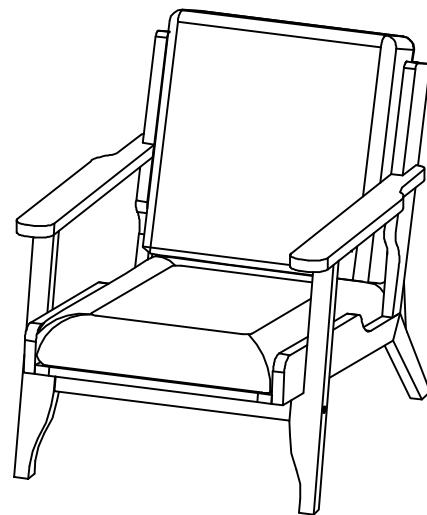

DISCLAIMER:

WHEN PROPERLY ASSEMBLED, THIS ITEM IS SAFE FOR INTENDED USE. SELLER IS NOT LIABLE FOR ANY DAMAGES RESULTING FROM ITEM BEING IMPROPERLY ASSEMBLED AFTER PURCHASE.

Assembly Procedures:

Step 1. Assemble the lounge on a flat, soft surface such as a carpet or cloth to prevent scratching the finish. Attach seat frame (P5) and back frame (P6) to the left arm (P2). Loosely tighten the bolts with open wrench (h).

(H2)x5 Short Bolts $\text{Ø}1/4\text{"x}2\text{"}$ 

(H3)x5 Lock Washers $1/4\text{"}$ 

(H4)x5 Big flat washers $1/4\text{"}$ (19mm) 

(H8)x1 Open Wrench 

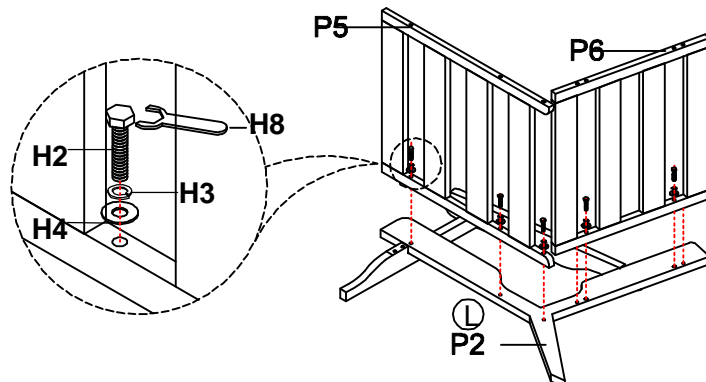

Step 2. Attach stretcher (P7) to the left arm (P2) as shown below. Loosely tighten the bolt with Allen wrench (H6).

(H1)x1 Long Bolts $\text{\O}1/4\text{"}\times3\text{"}$

(H3)x1 Lock Washers 1/4"

(H5)x1 Small flat washers 1/4" (12mm)

(H6)x1 Allen Wrench 1/4"

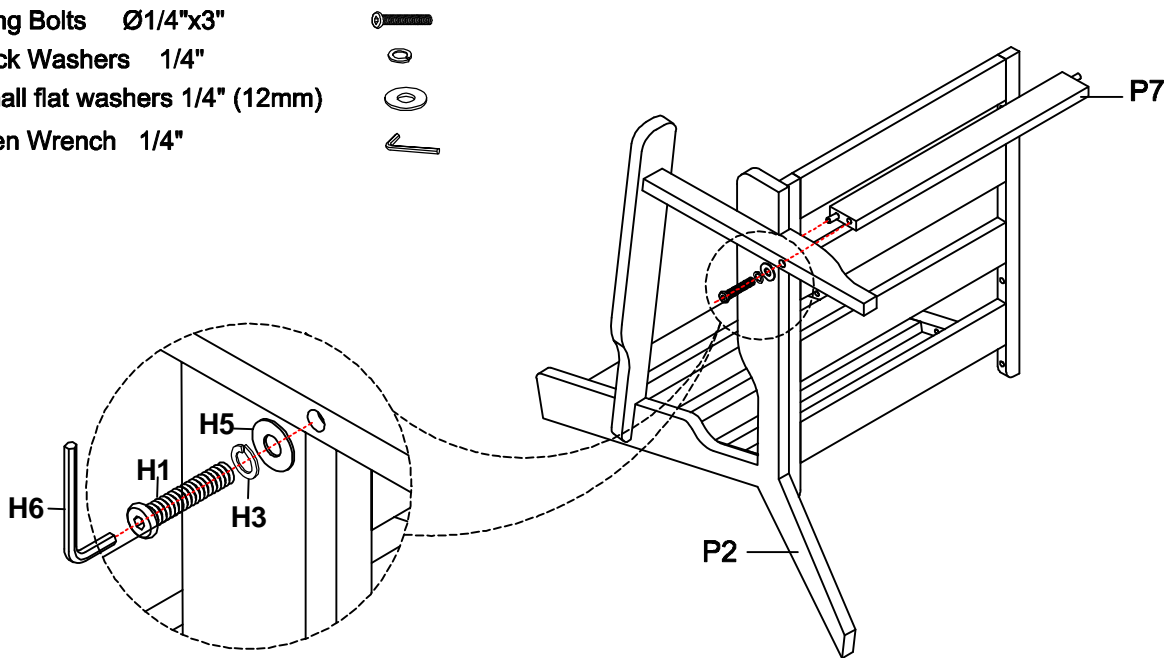

Step 3. Attach right arm (P1) to the assembled seat frame (P5), back frame (P6) and stretcher (P7) as shown below. Loosely tighten the bolts with open wrench (H8) as shown below.

(H2)x5 Short Bolts $\text{\O}1/4\text{"}\times2\text{"}$

(H3)x5 Lock Washers 1/4"

(H4)x5 Big flat washers 1/4" (19mm)

(H8)x1 Open Wrench

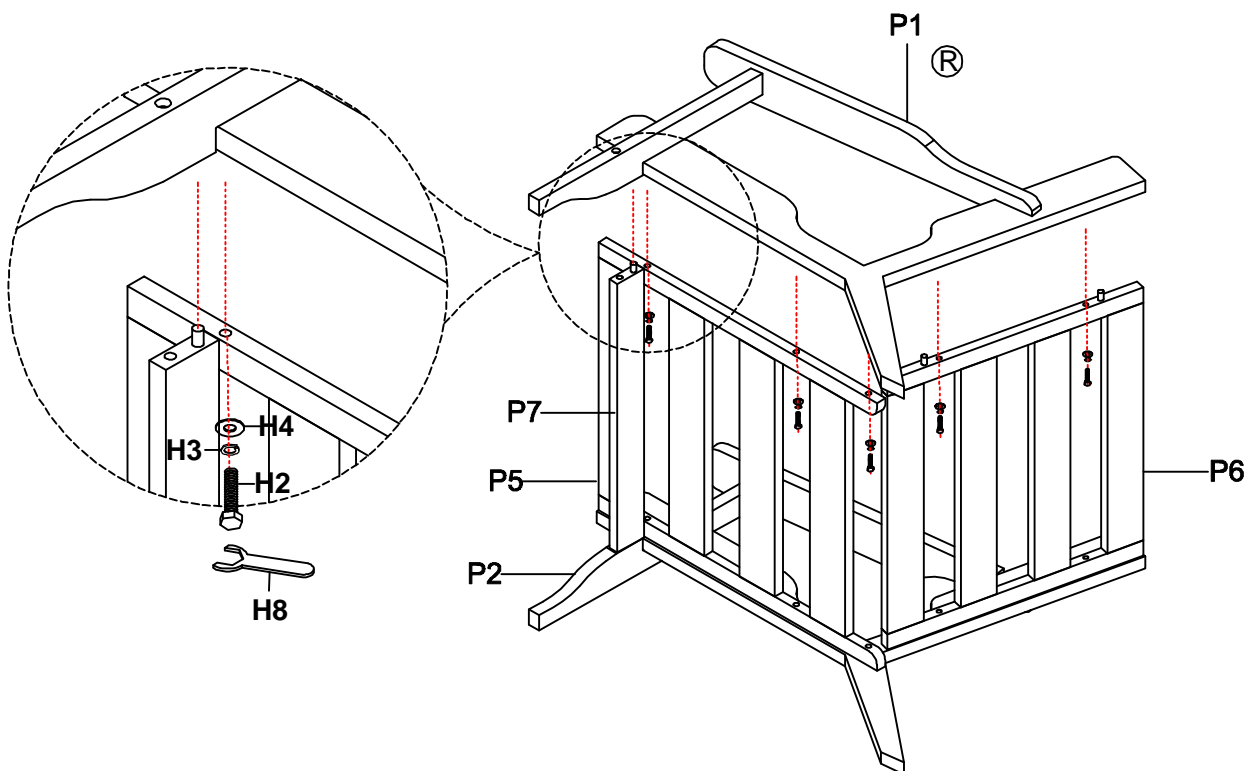

Step 4. Attach right arm (A) to stretcher (G) using bolt (a), lock washer (c) and flat washer (e). Loosely tighten the bolt with Allen wrench (f).

(H1)x1 Long Bolts Ø1/4"x3"



(H3)x1 Lock Washers 1/4"



(H5)x1 Small flat washers 1/4" (12mm)



(H6)x1 Allen Wrench 1/4"

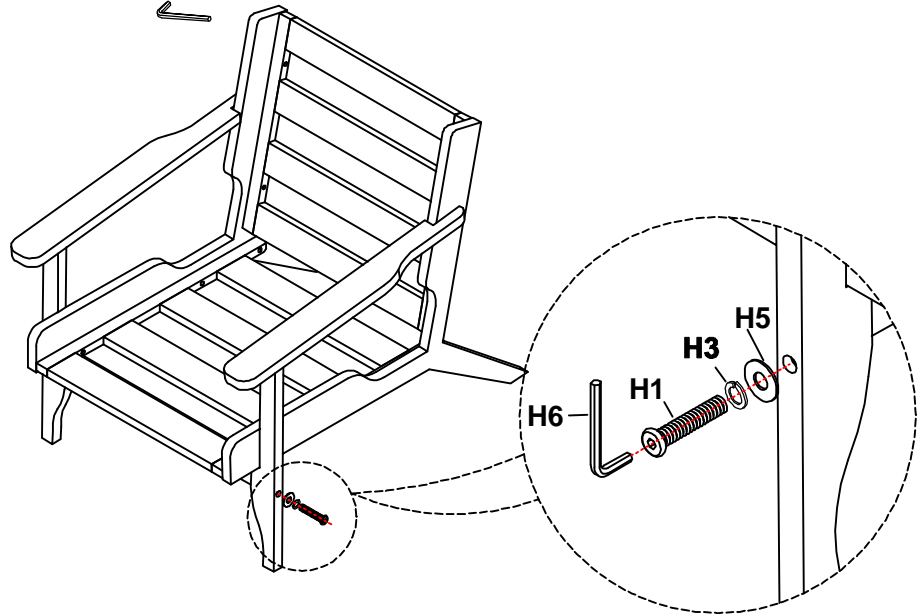

Step 5. Turn the assembled lounge to an upright position. Securely tighten all bolts with wrenches (H6, H8), but do not over tighten the bolts.

- 1) Attach wooden plugs (H7) to each bolt hole, tighten with rubber hammer to knock the wooden plug till its tighten. Note: use a soft cloth between the wooden plug and hammer to prevent damage to wooden plug finish.
- 2) Assembly is complete. Failure to follow these instructions may cause the bolts to misalign during assembly.
- 3) Put the seat cushion (P3) and back cushion (P4) on the assembled lounge.

(H7)x2 Wooden Plugs

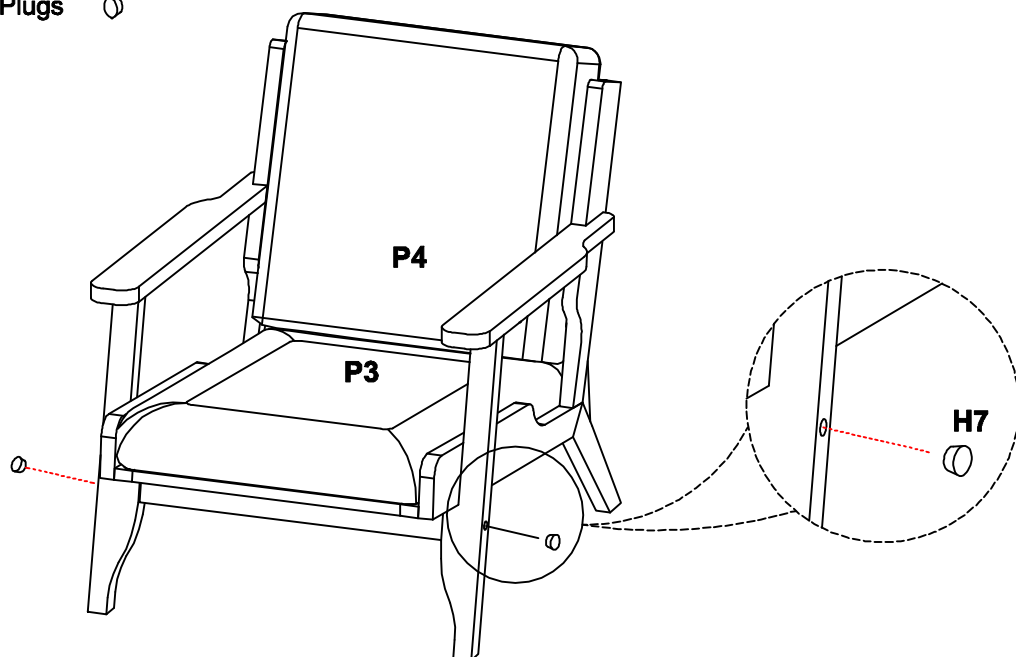

ADDITIONAL NOTE ABOUT SAFETY: BOLTS MAY LOOSEN DURING NORMAL EVERYDAY USE. THEY SHOULD BE PERIODICALLY INSPECTED AND RE-TIGHTENED TO PREVENT DAMAGE OR INJURY. ALWAYS CHECK TO ENSURE THAT ALL HARDWARE IS KEPT TIGHTENED.

Thank you for you purchase