





Important safety instructions:

- Please read carefully all instructions before assembly.
- For your safety and ease, assembly by two or more adults is recommended.
- Keep instructions for future use.



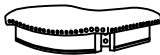

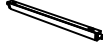
Pre-assembly:

- Do not discard any content until assembly is complete to avoid accidentally discarding small parts or hardware.
- Take out all parts and hardware from box.

Parts List

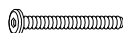
Item	Description	QTY
P1	Seat 	1
P2	Legs 	4
P3	Front Stretchers 	2
P4	Side Stretchers 	2

Hardware List

Item	Description	QTY
H1	JCBC SCREW 1/4" x 60mm 	8
H2	Spring Washer 1/4" x 13mm Ø 	8
H3	Flat Washer 1/4" x 19mm Ø 	8
H4	Pan Head Screw M4 x 38mm 	8
H5	Allen Key M4 x 65mm 	1

DISCLAIMER:

WHEN PROPERLY ASSEMBLED, THIS ITEM IS SAFE FOR INTENDED USE. SELLER IS NOT LIABLE FOR ANY DAMAGES RESULTING FROM ITEM BEING IMPROPERLY ASSEMBLED AFTER PURCHASE.

Assembly Procedures:

Step 1. Turn over seat (P1) on a flat, soft surface such as a carpet or cloth to prevent scratching the finish. Attach Legs (P2) to the Seat (P1) by using 2 JCBC screws (H1), 2 Spring Washers (H2) & 2 Flat Washers (H3) per each leg. Do not fully tighten JCBC Screws (H1) on this step.

H1	JCBC SCREW 1/4" x 60mm		8
H2	Spring Washer 1/4" x 13mm Ø		8
H3	Flat Washer 1/4" x 19mm Ø		8
H5	Allen Key M4 x 65mm		1

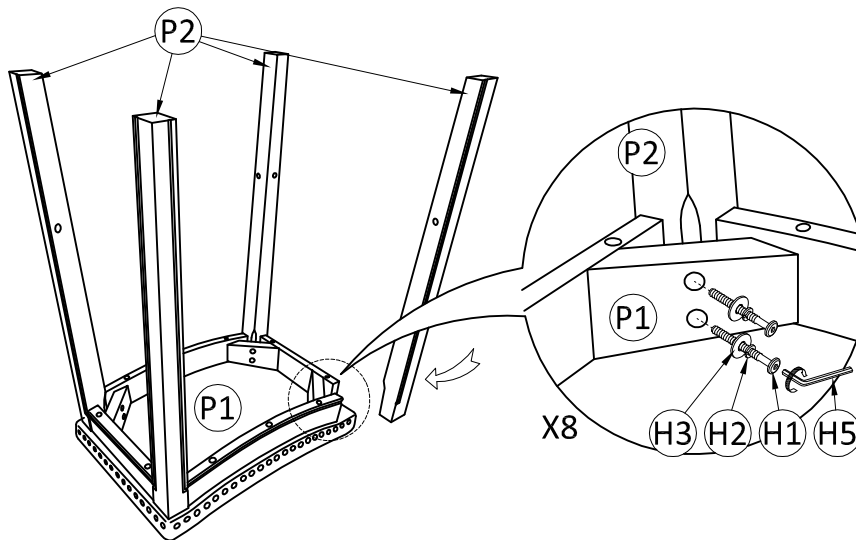

Step 2. Insert each Front Stretcher (P3) & Side Stretcher (P4) to the legs (P2) by using 2 Pan Head Screw (H4) per stretcher. Securely tighten all JCBC Screws (H1) with Allen Key (H5). Tighten all Pan Head Screw (H4) to the legs (P2) with screw driver (not provided).

H4	Pan Head Screw M4 x 38mm		8
----	--------------------------	---	---

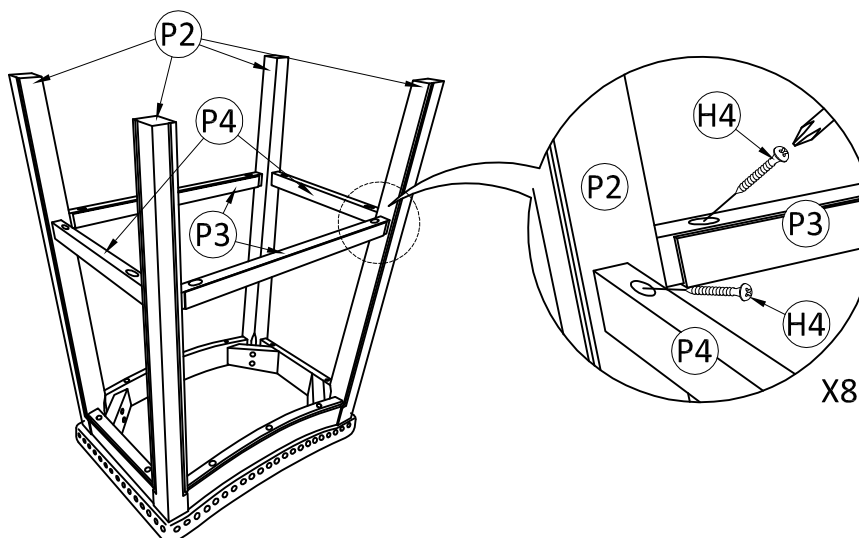

ADDITIONAL NOTE ABOUT SAFETY: BOLTS MAY LOOSEN DURING NORMAL EVERYDAY USE. THEY SHOULD BE PERIODICALLY INSPECTED AND RE-TIGHTENED TO PREVENT DAMAGE OR INJURY. ALWAYS CHECK TO ENSURE THAT ALL HARDWARE IS KEPT TIGHTENED.

Thank you for your purchase